

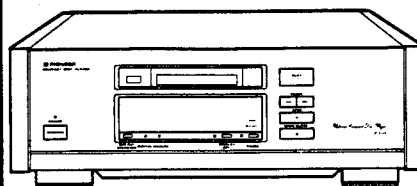

**PIONEER®**  
The future of sound and vision.

# Service Manual



ORDER NO.  
ARP2058

COMPACT DISC PLAYER

# PD-93

MODEL PD-93 HAS FOLLOWING VERSIONS:

Type	Power requirement	Export destination
KU/CA	AC120V only	U.S.A. and Canada
HEM	AC220V, 240V (switchable) *	European continent

\* Change the primary wiring of the power transformer.

- This manual is applicable to the KU/CA and HEM types.
- Ce manuel pour le service comprend les explications de réglage en français.
- Este manual de servicio trata del método ajuste escrito en español.

## CONTENTS

1. SAFETY INFORMATION .....	2	7. P.C.B's PARTS LIST .....	44
2. DISASSEMBLY .....	4	8. ADJUSTMENTS .....	49
3. OPERATION CHECK OF MAIN BOARD		8. RÉGLAGES .....	64
ASSEMBLY .....	7	8. AJUSTES .....	79
4. EXPLODED VIEWS AND PARTS LIST .....	8	9. IC DESCRIPTIONS (CXD1165Q) .....	94
5. LINE VOLTAGE SELECTION .....	19	10. PANEL FACILITIES .....	96
6. SCHEMATIC AND P.C. BOARDS		11. SPECIFICATIONS .....	97
CONNECTION DIAGRAMS .....	20		

**PIONEER ELECTRONIC CORPORATION** 4-1, Meguro 1-Chome, Meguro-ku, Tokyo 153, Japan

**PIONEER ELECTRONICS SERVICE INC.** P.O. Box 1760, Long Beach, California 90801 U.S.A.

**PIONEER ELECTRONICS OF CANADA, INC.** 505 Cochrane Drive, Markham, Ontario L3R 8E3 Canada

**PIONEER ELECTRONIC [EUROPE] N.V.** Keetberglaan 1, 2740 Beveren, Belgium

**PIONEER ELECTRONICS AUSTRALIA PTY. LTD.** 178-184 Boundary Road, Braeside, Victoria 3195, Australia TEL: [03] 580-9911

© PIONEER ELECTRONIC CORPORATION 1990

SI JUNE 1990 Printed in Japan

This service manual is intended for qualified service technicians; it is not meant for the casual do-it-yourselfer. Qualified technicians have the necessary test equipment and tools, and have been trained to properly and safely repair complex products such as those covered by this manual.

Improperly performed repairs can adversely affect the safety and reliability of the product and may void the warranty. If you are not qualified to perform the repair of this product properly and safely, you should not risk trying to do so and refer the repair to a qualified service technician.

**WARNING**

Lead in solder used in this product is listed by the California Health and Welfare agency as a known reproductive toxicant which may cause birth defects or other reproductive harm (California Health & Safety Code, Section 25249.5).

When servicing or handling circuit boards and other components which contain lead in solder, avoid unprotected skin contact with the solder. Also, when soldering do not inhale any smoke or fumes produced.

# 1. SAFETY INFORMATION

(FOR USA MODEL ONLY)

## 1. SAFETY PRECAUTIONS

The following check should be performed for the continued protection of the customer and service technician.

### LEAKAGE CURRENT CHECK

Measure leakage current to a known earth ground (water pipe, conduit, etc.) by connecting a leakage current tester such as Simpson Model 229-2 or equivalent between the earth ground and all exposed metal parts of the appliance (input/output terminals, screwheads, metal overlays, control shaft, etc.). Plug the AC line cord of the appliance directly into a 120V AC 60Hz outlet and turn the AC power switch on. Any current measured must not exceed 0.5mA.

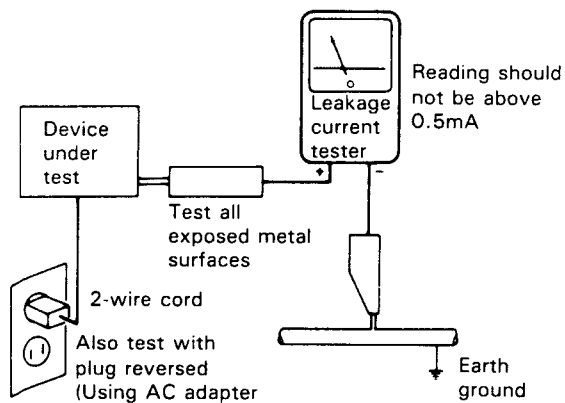

AC Leakage Test

ANY MEASUREMENTS NOT WITHIN THE LIMITS OUTLINED ABOVE ARE INDICATIVE OF A POTENTIAL SHOCK HAZARD AND MUST BE CORRECTED BEFORE RETURNING THE APPLIANCE TO THE CUSTOMER.

## 2. PRODUCT SAFETY NOTICE

Many electrical and mechanical parts in the appliance have special safety related characteristics. These are often not evident from visual inspection nor the protection afforded by them necessarily can be obtained by using replacement components rated for voltage, wattage, etc. Replacement parts which have these special safety characteristics are identified in this Service Manual.

Electrical components having such features are identified by marking with a  $\Delta$  on the schematics and on the parts list in this Service Manual.

The use of a substitute replacement component which does not have the same safety characteristics as the PIONEER recommended replacement one, shown in the parts list in this Service Manual, may create shock, fire, or other hazards.

Product Safety is continuously under review and new instructions are issued from time to time. For the latest information, always consult the current PIONEER Service Manual. A subscription to, or additional copies of, PIONEER Service Manual may be obtained at a nominal charge from PIONEER.

(FOR EUROPEAN MODEL ONLY)

VARO!

AVATTAESSA JA SUOJALUKITUS OHITETTAESSA OLET ALTTIINA NÄKYMÄTTÖMÄLLE LASERSÄTEILYLLE. ÄLÄ KATSO SÄTEESEEN.

ADVERSEL:

USYNLIG LASERSTRÅLING VED ÅBNING NÅR SIKKERHEDSAFBRYDERE ER UDE AF FUNKTION. UNDGÅ UDSÆTTELSE FOR STRÅLING.

VARNING!

OSYNLIG LASERSTRÅLING NÅR DENNA DEL ÄR ÖPPNAD OCH SPÄRREN ÄR URKOPPLAD. BETRAKTA EJ STRÅLEN.



LASER  
Kuva 1  
Lasersäteilyn  
varoituserkki

WARNING!

DEVICE INCLUDES LASER DIODE WHICH EMITS INVISIBLE INFRARED RADIATION WHICH IS DANGEROUS TO EYES. THERE IS A WARNING SIGN ACCORDING TO PICTURE 1 INSIDE THE DEVICE CLOSE TO THE LASER DIODE.



LASER  
Picture 1  
Warning sign for  
laser radiation

IMPORTANT

THIS PIONEER APPARATUS CONTAINS LASER OF HIGHER CLASS THAN 1. SERVICING OPERATION OF THE APPARATUS SHOULD BE DONE BY A SPECIALLY INSTRUCTED PERSON.

LASER DIODE CHARACTERISTICS  
MAXIMUM OUTPUT POWER: 5 mw  
WAVELENGTH: 780-785 nm

LABEL CHECK

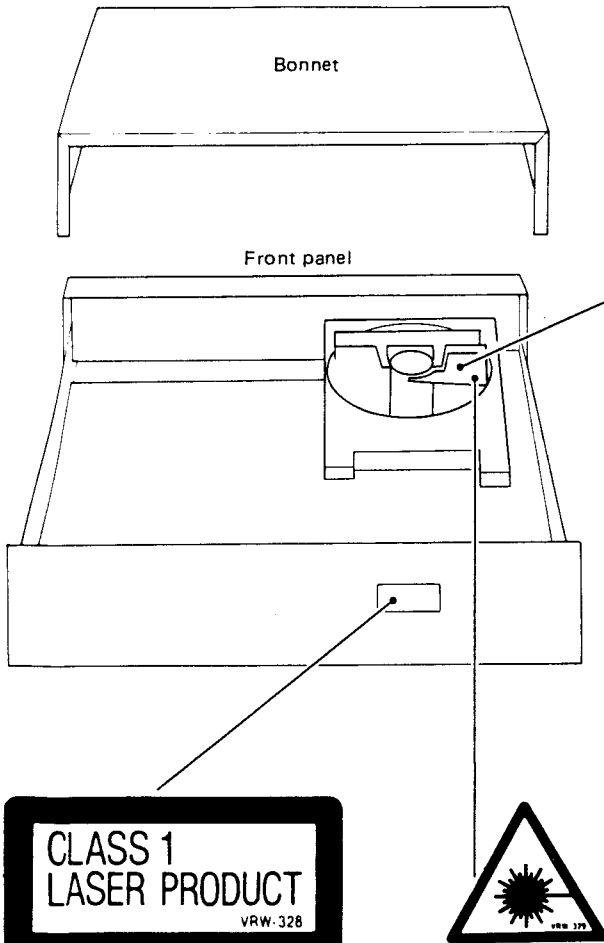

HEM model

ADVARSEL  
USYNLIG LASERSTRÅLING VED ÅBNING NÅR SIKKERHEDSAFBRYDERE ER UDE AF FUNKTION. UNDGÅ UDSÆTTELSE FOR STRÅLING.  
VORSICHT!  
UNSICHTBARE LASER-STRÄHLUNG TRITTS AUS, WENN DECKEL (ODER KLAPPE) GEÖFFNET IST! NICHT DEM STRAHL AUSSETZEN!  
VRW1094

Additional Laser Caution

1. Laser Interlock Mechanism  
The ON/OFF status of the clamp switch (S102) for detecting loading completion is detected by the system microprocessor, and the design prevents laser diode oscillation when the clamp switch is OFF. Thus, the interlock will no longer function if the clamp switch (S102) is deliberately shorted. In the test mode the interlock mechanism will not function (refer to page 49). Laser diode oscillation will continue if pin 4, 5, or 29 of CXA1081S (IC301) is connected to ground or the terminals of Q1 are shorted to each other (fault condition).
2. If the fault condition described in 1 is induced with the cover removed and the objective lens extending past the outer circumference of the disc clamper diameter, close viewing of the objective lens with the naked eye will cause exposure to a Class 1 or higher laser beam.

## 2. DISASSEMBLY

### ● REMOVAL OF FRONT PANEL

1. Keep the side boards (L) and (R) apart from the upper plate by loosening the screws ((L, 4) (R, 4)) fixing them. (Be sure not to remove yet since the lead wire for ground is attached to the side sash on the side board (L) and (R).)
2. Remove the upper plate. (Remove the four black screws (upper side) and four copper screws (rear side).)
3. Remove the screws (A<sub>1</sub>) and (A<sub>2</sub>) fixing the ground lead wire for side sash. (Refer to Fig. 2-1.)
4. Remove the side boards (L) and (R).
5. Turn the power to draw out the tray. (Refer to Note 1 when opening the tray manually.)
6. Remove the tray name plate. (Loosen the screw (B<sub>1</sub>) and (B<sub>2</sub>) enough.)
7. Remove the tray fixing plate (Screws (C<sub>1</sub>), (C<sub>2</sub>))
8. Remove the front panel (Remove the three screws of upper side and the four screws of lower side.)

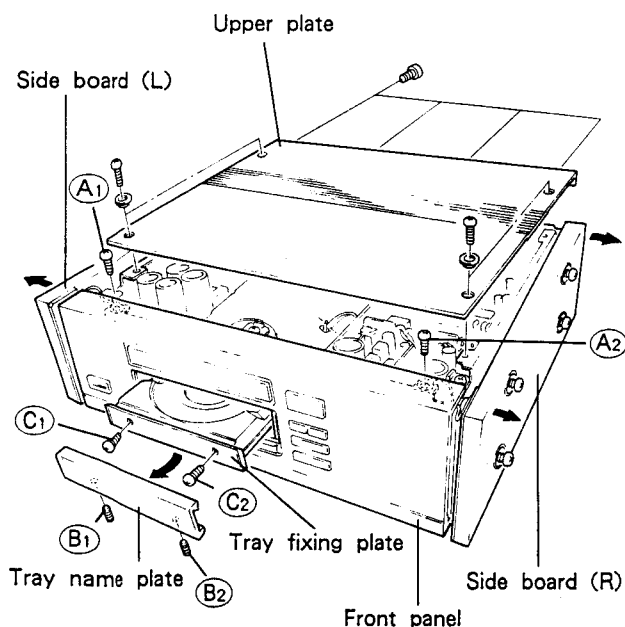

Fig. 2-1.

### Note 1. How to open the tray manually

1. Loosen the screw (E) fixing the clamp motor.
2. Taking care not to drop the iron ball of the tip of the gear section of the clamp motor as shown in Fig. 2-2, keep the engaging section (G) of gear apart from the unit by tilting the clamp motor in the direction of arrow.
3. Turn the clamp cam counterclockwise to the position where the leaf switch turns on. (Set to the state that the clamp holder is raised.)
4. Mount the clamp motor again. (Drive the screw (E).)
5. Push the tray from behind to open it.

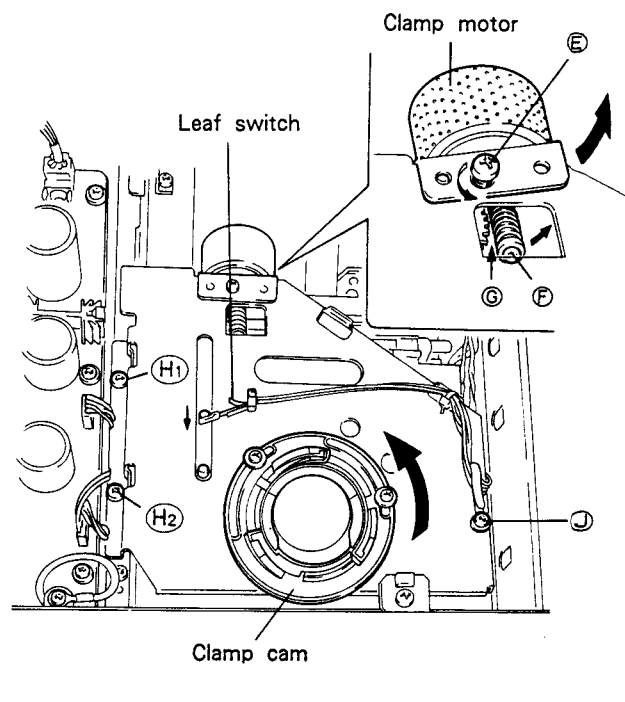

Fig. 2-2.

● REMOVAL OF TRAY ASSEMBLY

1. Remove the upper plate as in the steps 1 and 2 of "REMOVAL OF FRONT PANEL".
2. Remove by turning over the clamp mechanism assembly. (Screws  $H_1$ ,  $H_2$  and  $J$ , Refer to Fig. 2-2.)
3. Remove the fixing screws  $K_1$  and  $K_2$  of the tray assembly and remove the slide base from the slider unit of the loading mechanism assembly by pushing the claw  $L$ . (Refer to Fig. 2-3).
4. Remove the tray assembly by drawing out from the front panel.

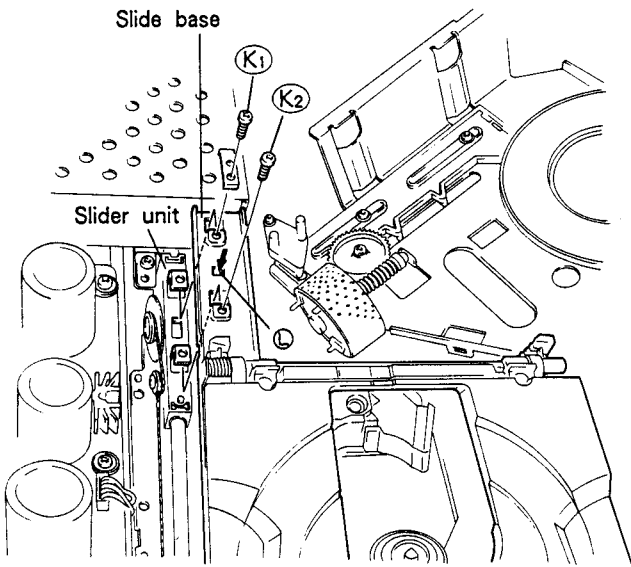

Fig. 2-3.

● REMOVAL OF PICKUP ASSEMBLY

1. Remove the upper plate as in the steps 1 and 2 of "REMOVAL OF FRONT PANEL".
2. Remove by turning over the clamp mechanism assembly. (Screws  $H_1$ ,  $H_2$  and  $J$ , Refer to Fig. 2-2.)
3. Move the tray to the open position. (Refer to Note 1.)
4. Remove the fixing screws  $M$  (2) and the plastic rivet  $N$  of the pickup assembly in this state. (Refer to Fig. 2-4.)

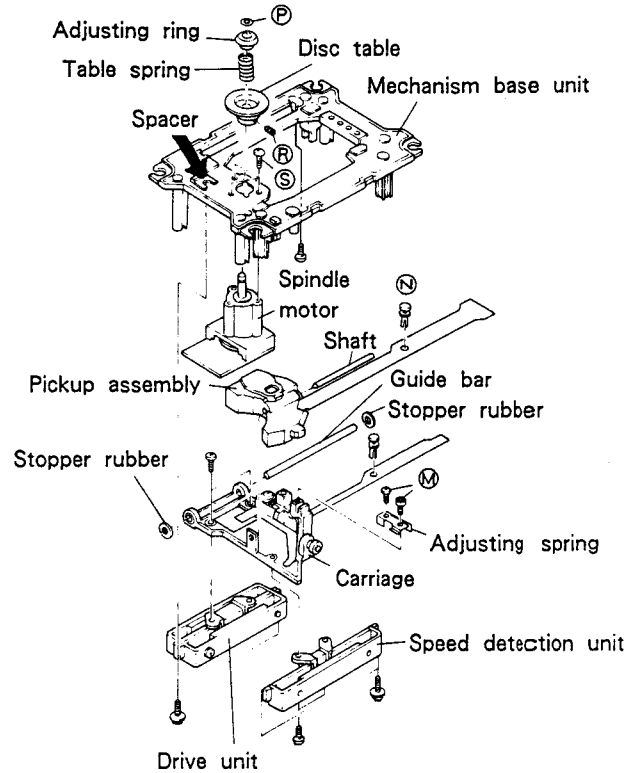

Fig. 2-4.

● INSTALLATION OF DISC TABLE

Cut the spacer shown by the arrow (refer to Fig. 2-4.) with a nipper (the rear side), enter it between the disc table and the mechanism base, and screw it. Torque over 5 kgcm to screw.

(Reference) In the case of no torque driver, tighten firmly the hexagonal screw, press the disc table from the upper side, and check that it does not slip down.

Remove the spacer after installing the disc table. (The spacer is  $1\frac{1}{16}$  in thickness.)

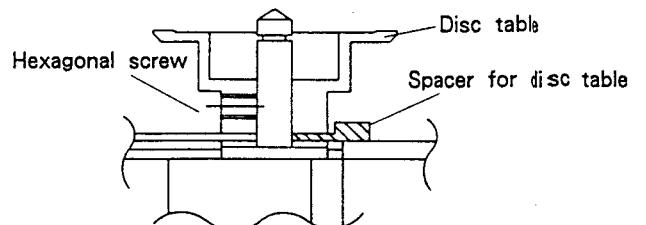

● REMOVAL OF SPINDLE MOTOR

1. Remove the base (alias bottom plate) (17 screws).
2. Remove the split washer ① fixing the adjusting ring. (Refer to Fig. 2-5.)  
(Remove it with a tweezers while pressing the adjusting ring ??.)
3. Move the tray to the open position. (Refer to Note 1.)
4. Loose the screws ② of the disc table from the opening part of the front panel with the hexagonal driver and remove the disc table.
5. Remove the fixing screws ③ (3) of the spindle motor.
6. Remove the lead wires (7) wired as shown in Fig. 2-5, with a soldering iron.

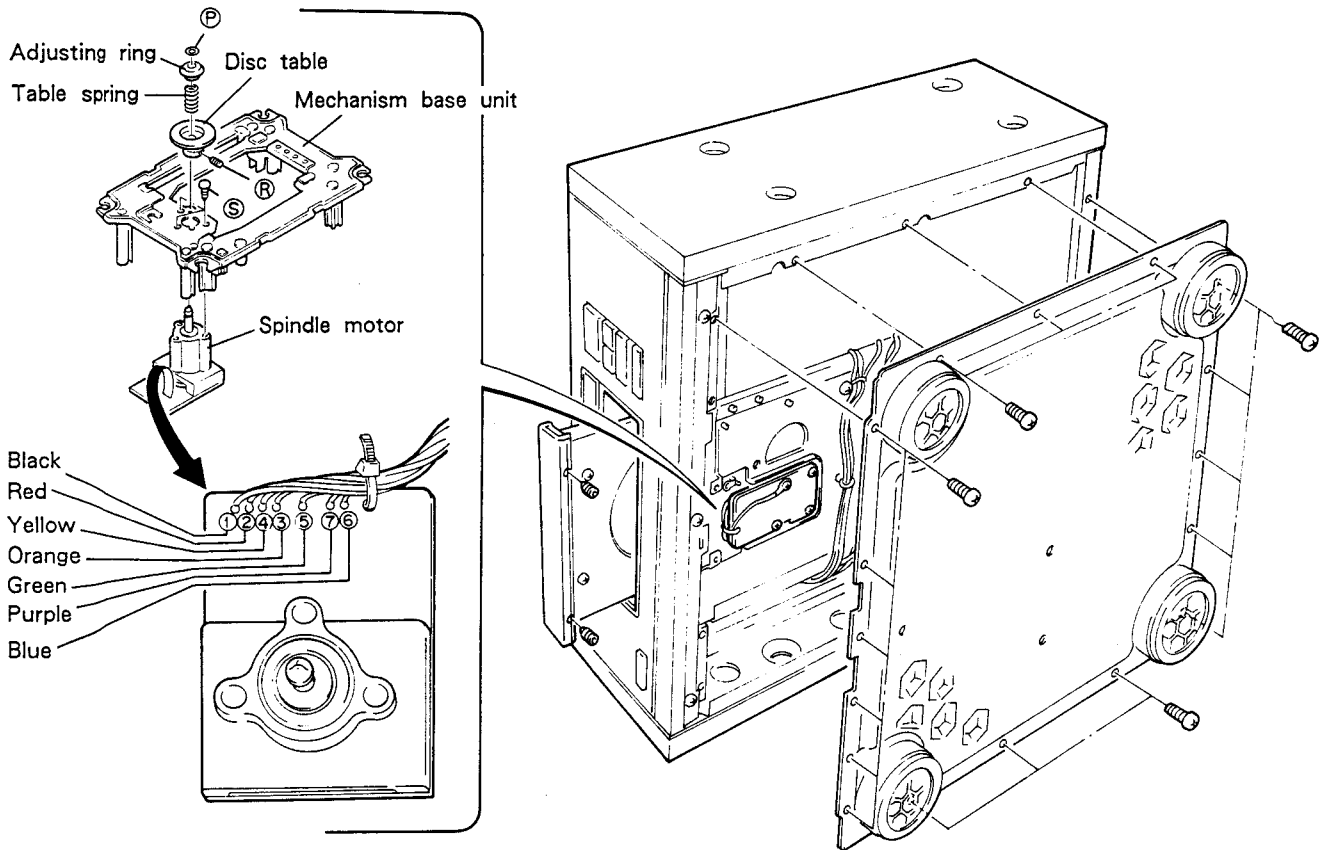

Fig. 2-5.

● REMOVAL OF SERVO MECHANISM ASSEMBLY

1. Remove the tray assembly. (Refer to REMOVAL OF TRAY ASSEMBLY.)
2. Remove the slide guide. (Screws T<sub>1</sub> and T<sub>2</sub>, refer to Fig. 2-6.)
3. Remove the four screws (U<sub>1</sub> to U<sub>4</sub>) fixing the servo mechanism assembly.
4. Remove the flexible wire from the CN301 and CN302, and remove the servo mechanism assembly.

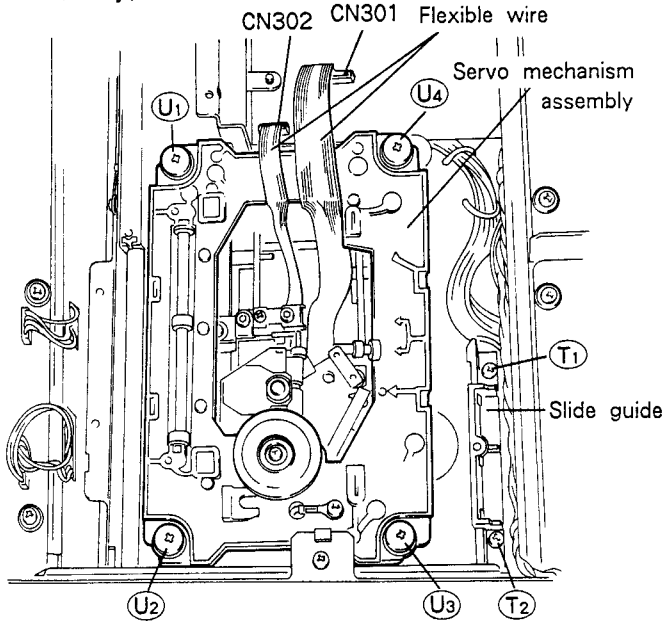

Fig. 2-6.

● REMOVAL OF LOADING MOTOR

1. Remove the loading mechanism assembly.

● REMOVAL OF LOADING MECHANISM ASSEMBLY

1. Remove the servo mechanism assembly. (Refer to REMOVAL OF SERVO MECHANISM ASSEMBLY.)
2. Remove the screws V<sub>1</sub> and V<sub>2</sub> fixing the loading mechanism assembly and the lead wire from cord stopper W. (Refer to Fig. 2-7.)
3. Move the loading mechanism assembly backward a little and remove it by raising the end of front panel.

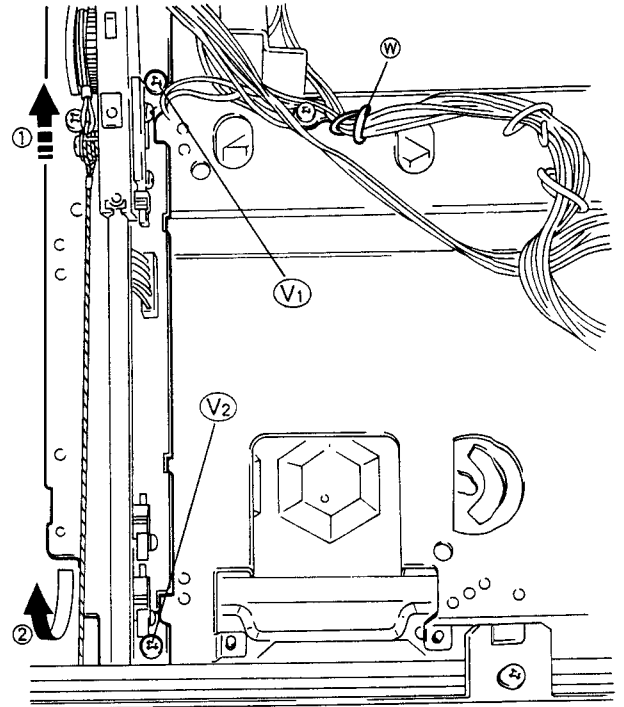

Fig. 2-7.

3. OPERATION CHECK OF MAIN BOARD ASSEMBLY

1. Remove the three assemblies of the audio monaural boards (Lch), (Rch) and the power supply board (A). (Remove for the output pin jack portion with a soldering iron.)
2. Remove the main shield plate (6 screws). It is possible to turn on the power and check the servo circuit in this state. (Refer to Fig. 3-1 for the position to install each assembly mentioned above.)

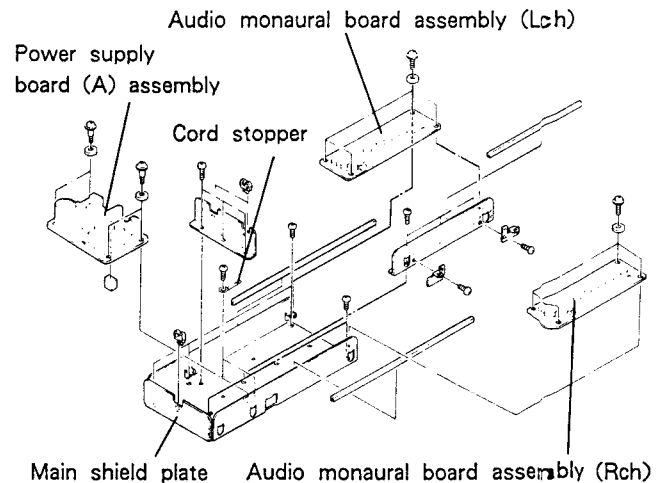

Fig. 3-1.

## 4. EXPLODED VIEWS AND PARTS LIST

### NOTES:

- Parts without part number cannot be supplied.
- The  $\Delta$  mark found on some component parts indicates the importance of the safety factor of the part. Therefore, when replacing, be sure to use parts of identical designation.
- Parts marked by "⊙" are not always kept in stock. Their delivery time may be longer than usual or they may be unavailable.

### 4.1 Parts List of Exterior(1)

Mark	No.	Symbol & Description	Part No.	Mark	No.	Symbol & Description	Part No.
	1	Name plate	AAM1001		41	Tray fixing plate	PNS1008
	2	LED lens	AMR1160		42	Clamp knob	PNW1236
	3	Screw	AMZ40P180FRD		43	Joint	
	4	Screw	BBT30P080FCU		44	Wood collar	PNW1238
	5	Screw	BBZ30P060FCC		45	Lens(A)	PNW1460
	6	Screw	BBZ30P080FRD		46	Control panel	PNW1579
	7	Screw	BBZ30P080FZK		47	Power button	PNW1580
	8	Screw	IBZ30P080FCC		48	Operating instructions (English)	PRB1121(KU/CA type)
	9	Screw	IBZ30P080FCC			(English/French/German/ Italian/Dutch/Spanish/ Swedish/Portugese)	PRE1117(HEM type)
	10	Select button	PAC1325		49	Caution label	.....
	11	Main button assembly	PAD1053		50		.....
	12	FL sheet	PAM1290(KU/CA type) PAM1251(HEM type)		51	Clamp caution label	.....
	13	Display window	PAM1344	⊙	52	Main operation board assembly	PWZ1742
	14	Front panel	PAN1162(KU/CA type) PAN1161(HEM type)		53	Remote control unit	PWW1045
	15	Side sash	PAN1151		54	Leg assembly	AMR1159
	16	Tray name plate	PAN1152		55	Servo mechanism assembly	
	17	Screw	PBA1017		56	Loading mechanism assembly	
	18		.....		57	Tray assembly	
	19	Plate spring A			58	Clamp mechanism assembly	
	20	Plate spring B			59	Screw	RBA-093
	21	Connection cord	PDE1032		60	Battery	
	22	Cushion rubber			61	Washer	WA42N120W050
	23	Vibration isolating rubber			62	Plastic bag	Z21-037
	24	Side rubber(R)	PEB1118		63	Sheet	Z23-024
	25	Side rubber(L)	PEB1119		64	Screw	ZMD30H040FBI
	26	Protector(F)	PHA1111		65	Battery cover	PZN1007
	27	Protector(R)	PHA1112		66	Sub operation board assembly	
	28	Spacer	PHC1018		67	LED board assembly	
	29	Sheet	PHC1022		68	Screw	PYC30P100FMC
	30	Upper plate	PHC1047		69	Play lens	PNW1258
	31	Packing case	PHG1494(KU/CA type) PHG1493(HEM type)		70	Stop rubber	PEB1140
	32	Collor	PLA1029		71	Plastic bag	Z21-013
	33	Side board(L)	PMM1019(KU/CA type) PMM1027(HEM type)		72	Front panel assembly	PEA1090(KU/CA type) PEA1091(HEM type)
	34	Side board(R)	PMM1020(KU/CA type) PMM1028(HEM type)				
	35	Screw	PMZ40P060FMC				
	36	Base					
	37	Vibration isolating material S					
	38	Cushion					
	39	Nois absorption material	PNW1102				
	40	Upper plate	PNS1002				



# WHEN RE-TRANSPORTING THE UNIT

Mount the screws and knobs removed to the original positions.  
Perform in the reverse order of removals.

**1. Mount the fixing screw for transformer on the rear side.**

**2. Mount the fixing knob and screw on the bottom side.**

- ① Stand this mechanism sideways.
- ② Match the mark  $\Delta$  on the gray knob and the mark  $\Delta$  on the bottom side, and insert the knob. Insert so as to enter the pole of the bottom lid into the round hole of the knob's end.
- ③ Turn the knob counterclockwise.
- ④ Match the screw holes, insert the screw and tighten it with a phillips screwdriver.

**3. Remove the tray and insert the spacer for transport.**

**Note:** Tighten the fixing knob and screw of the bottom lid, before inserting the spacer for transport.

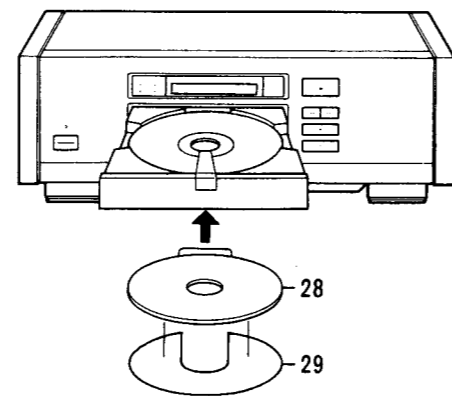
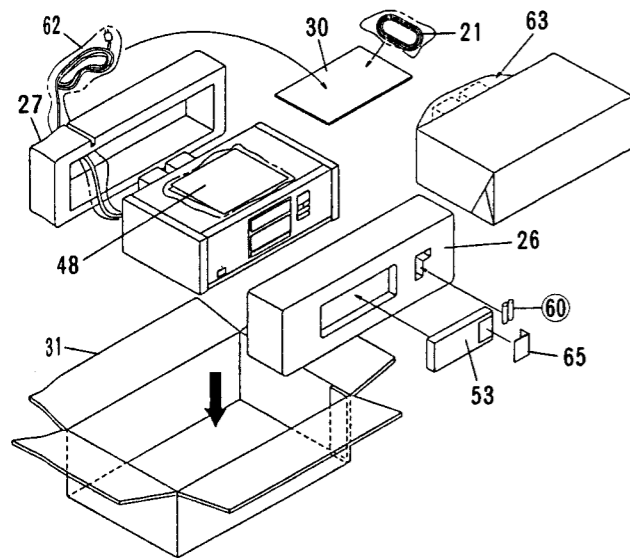
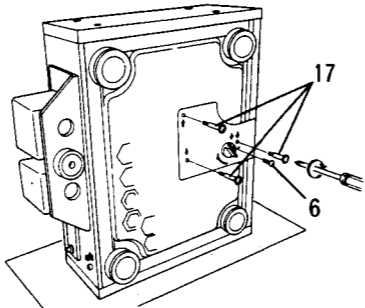
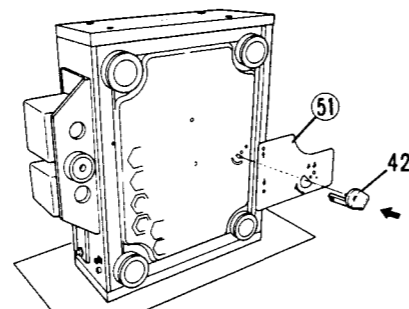
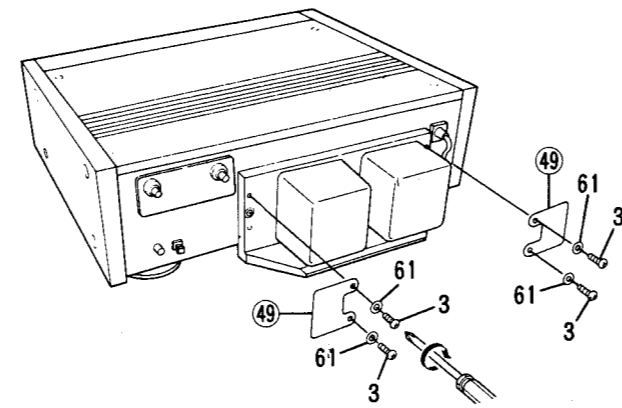

29 is partially put on on 28 with a both-sides tape to prevent from damage by the vibration in transport.

A

Servo mechanism assembly  
(For details, refer to pages 14 to 16.)

B

C

D

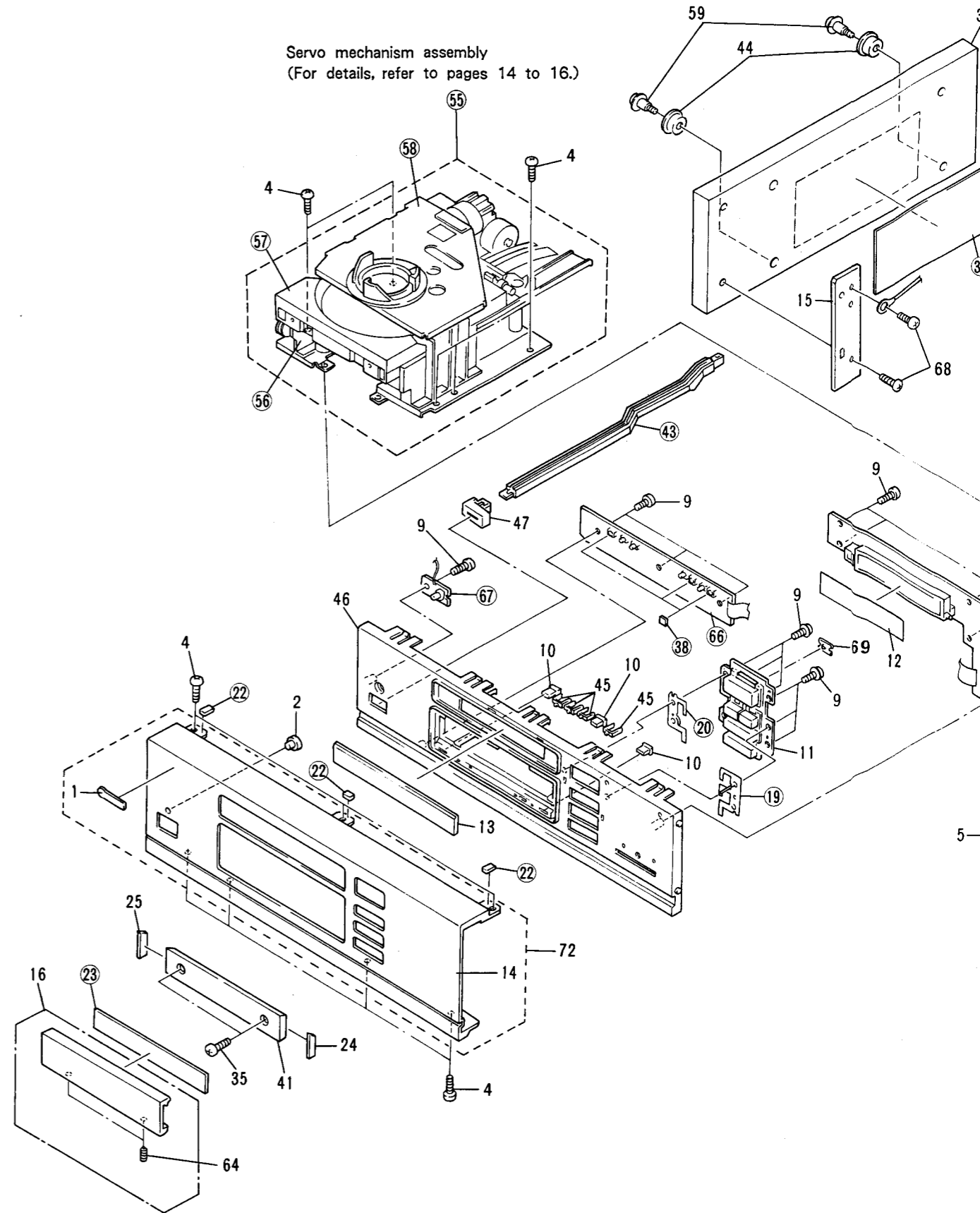

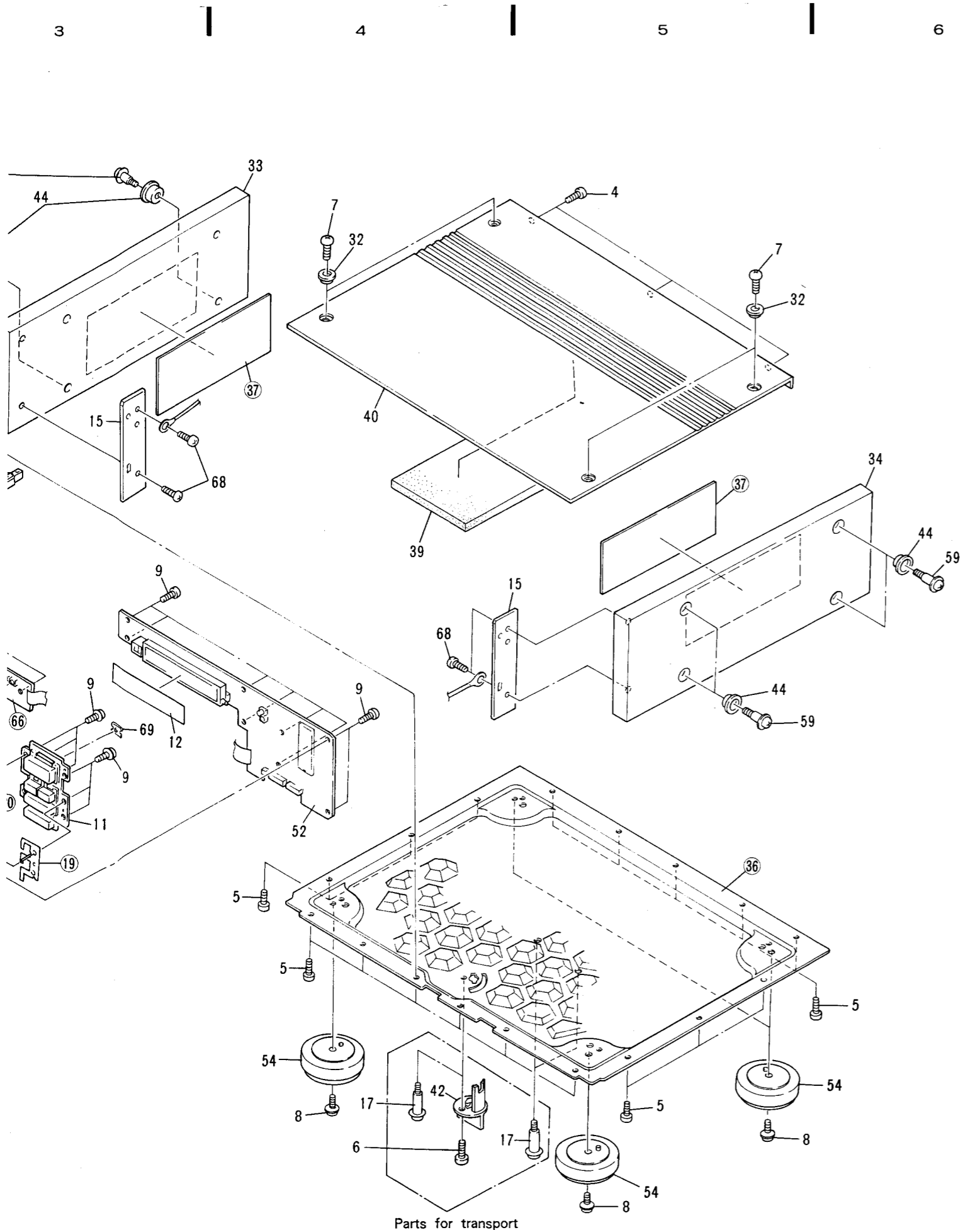

Parts for transport

11-12-

3

4

5

6

A

B

C

D

3

4

5

6

4.2 EXTERIOR (2)

For HEM type

Note: No.25 is a four-piece set (A, B, C and D).

Note: No.26 is a four-piece set (E, F, G and H).

Parts for transport

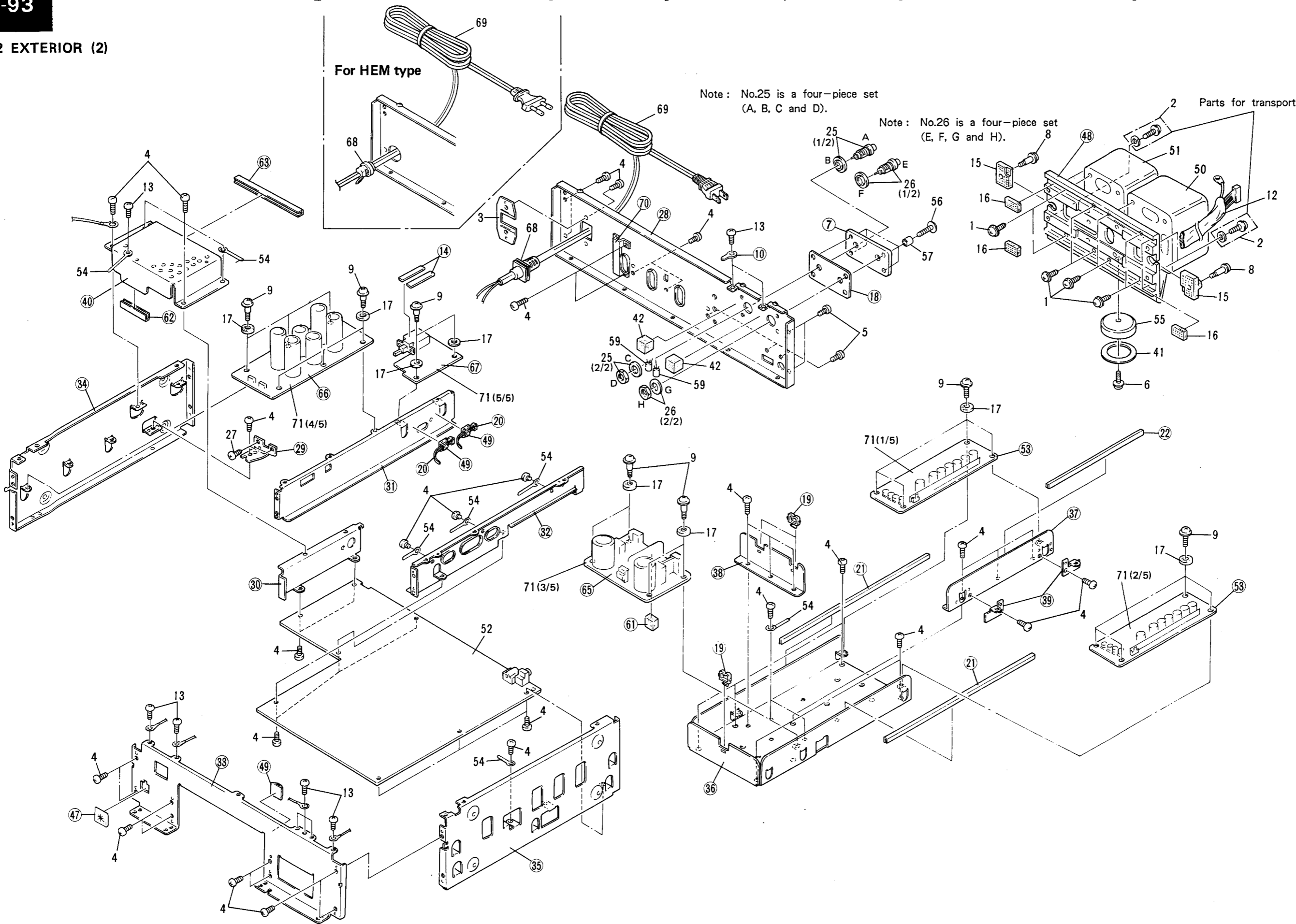

4.2 Parts List of

Mark No. Symbo

Mark	No.	Symbo
	1	Screw
	2	Screw
△	3	AC cord s
	4	Screw
	5	Screw
	6	Screw
	7	Pin jack
	8	Screw(A)
	9	Screw(B)
	10	BS-board
	11	Shrink sh
	12	Shrink sh
	13	Screw
	14	Vibration rubber(B)
	15	Damper ru
B	16	Damper ru
	17	Rubber wa
	18	RCA Dampe
	19	Wire clip
	20	Binder
	21	Edging A
	22	Edging B
	23	
	24	
	25	IP Pin ja
	26	IP Pin ja
	27	Screw
	28	Rear base
	29	Switch an
	30	Sub angle
	31	Mechanism
	32	Mechanism
	33	Front ang
	34	Side plat
	35	Side plat
	36	Main shie
	37	Audio shi
	38	Power sup
	39	P. C. B ang
	40	Power sup
	41	Stopper
	42	Cushion
	43	
	44	
	45	
	46	
	47	Damper
	48	Rear angl
D	49	Binder ho
△	50	Power tra

#### 4.2 Parts List of Exterior(2)

Mark	No.	Symbol & Description	Part No.	Mark	No.	Symbol & Description	Part No.
A	1	Screw	AMZ40P080FMC	△	51	Power transformer S/24VA	PTT1158(KU/CA)
	2	Screw	AMZ40P180FRD				PTT1157(HEM)
△	3	AC cord spacer	ANG1153(KU/CA type)	⊙△	52	Main board assembly	PWM1285
	4	Screw	BBZ30P060FCC		53	Audio monaural board assembly	
	5	Screw	BBZ30P080FCC		54	Cord clamber	RNH-184
	6	Screw	IBZ30P120FCC		55	Insulator	VLL1038
	7	Pin jack name plate					
	8	Screw(A)	PBA1008		56	Screw	Z39-012
	9	Screw(B)	PBA1014		57	Bush	Z39-013
	10	BS-board lug			58		.....
	11		.....	△	59	Capacitor	CQSF101J50
	12	Shrink shield 450L	PDM1003		60		.....
	13	Screw	PDZ30P060FCC		61	Rubber spacer	
	14	Vibration isolating rubber(B)			62	Edging C	
	15	Damper rubber(A)	PEB1054		63	Edging D	
					64		.....
B	16	Damper rubber(B)	PEB1055		65	Power supply board (A) assembly	
	17	Rubber washer	PEB1136				
	18	RCA Damper rubber			66	Power supply board (S) assembly	
	19	Wire clip			67	Primary board assembly	
	20	Binder			68	Strain relief	CM-22C(KU/CA type)
	21	Edging A					CM-22B(HEM type)
	22	Edging B		△	69	AC power cord	VDG1042(KU/CA type)
	23		.....				PDG1003(HEM type)
	24		.....		70	S cover	
	25	1P Pin jack L	PKB1012	⊙△	71	Audio board assembly	PWM1286
	26	1P Pin jack R	PKB1013				
	27	Screw	PMZ30P060FCC				
	28	Rear base					
	29	Switch angle					
	30	Sub angle					
C	31	Mechanism angle L					
	32	Mechanism angle R					
	33	Front angle					
	34	Side plate L					
	35	Side plate R					
	36	Main shield plate					
	37	Audio shield plate					
	38	Power supply shield plate					
	39	P.C.B angle					
	40	Power supply cover					
	41	Stopper	PNM-051				
	42	Cushion	PNM1008				
	43		.....				
	44		.....				
	45		.....				
	46		.....				
	47	Damper					
	48	Rear angle					
D	49	Binder holder					
△	50	Power transformer A/13VA	PTT1156(KU/CA) PTT1155(HEM)				

#### 4.3 Parts List of Mechanism unit

Mark	No.	Symbol & Description	Part No.	Mark	No.	Symbol & Description	Part No.
	1	Screw	BBZ30P060FCC		51	Drive pulley	PNW1212
	2	Screw	IBZ30P080FCC		52	Pulley	PNW1213
	3	Screw	PBA1020		53	L guide	PNW1214
	4	Screw	PBA1024		54	Loading board assembly	
	5	Spring	PBH1027		55	Screw	BBZ30P080FCC
	6	Spring	PBH1028		56	Screw	PBA-125
	7	Spring	PBH1029		57	Slide cam spring	PBH1026
	8	Spring	PBK1021		58	Slide base	
	9	Spring	PBK1022		59	Earth plate	
	10	Plastic rivet	PBM-015		60	Slide cam	PNW1217
	11	Cushion rubber			61	Interlocking lever unit	PNW1218
	12	Vibration isolating rubber(B)			62	Tray	PNW1745
	13	Stopper rubber	PEB1035		63	Disc plate	PNW1581
	14	Hold rubber	PEB1048		64	Steel ball φ4	PBP-001
	15	Disc table	PLA1024		65	Screw	PMZ20P080FMC
	16	Aligning ring	PLA1025		66	Screw	PMZ26P040FMC
	17	Guide bar	PLA1026		67	York	PNB1049
	18	Shaft	PLA1027		68	Clamp base	
	19	Roller	PLM1001		69	Motor holder	
	20	Magnet			70	Disc cushion	PNM1025
	21	Screw	PMZ26P030FCU		71	Clamper	
	22	Screw	PMZ26P060FCU		72	Worm	PNW1220
	23	Screw	PMZ30P080FCU		73	Worm wheel	PNW1221
	24		.....		74	Clamp drive plate	PNW1222
	25		.....		75	Clutch	PNW1223
	26	Adjust lever	PNB1048		76	Clamp cam	PNW1224
	27	Linear flexible board			77	Clamp holder	PNW1225
	28	Carriage			78	Reef switch	VSK-015
	29	Mechanism base unit			79	Drive unit	PYY1038
	30	Stopper	PNW1432		80	Speed sensor unit	PYY1039
	31	Pickup assembly	PWY1004		81	Motor assembly	PYY1097
	32	Spindle motor	PXM1005		82	Motor assembly	PYY-507
	33		.....		83	Float spring	PBH1030
	34	Washer	WT25D047D025		84	Float spring(F)	PBH1097
	35	Washer	WT40D065D025		85	Damper rubber	PEB1036
	36	Screw	ZMD30H040FBT		86	Slide guide	
	37	Screw	IBZ30P060FCC		87	Cord clamber	RNH-184
	38	Wire spring	PBH1025		88	Mechanism chassis	
	39	Wire unit	PBL1001		89	Mechanism support	
	40		.....		90	Earth lead unit	
	41	Cushion rubber			91	Screw	PBA1021
	42		.....		92		.....
	43	Belt	PEB1037		93	Screw	IBZ30P100FCC
	44	Stopper	PEB1076		94	Screw	PDZ30P060FCC
	45	Guide bar	PLA1028				
	46		.....				
	47	Holder					
	48	Loading base					
	49	Slider unit	PNW1210				
	50	Gear pulley	PNW1211				

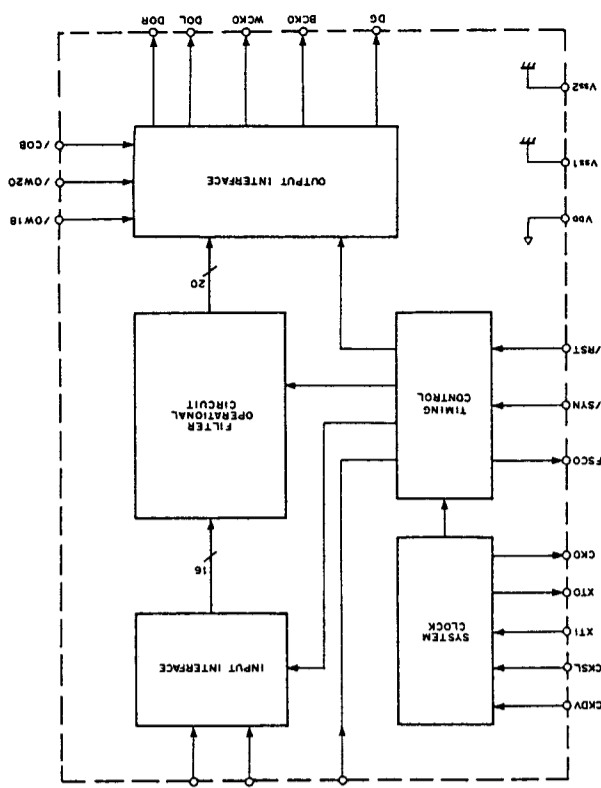

SM5813AP

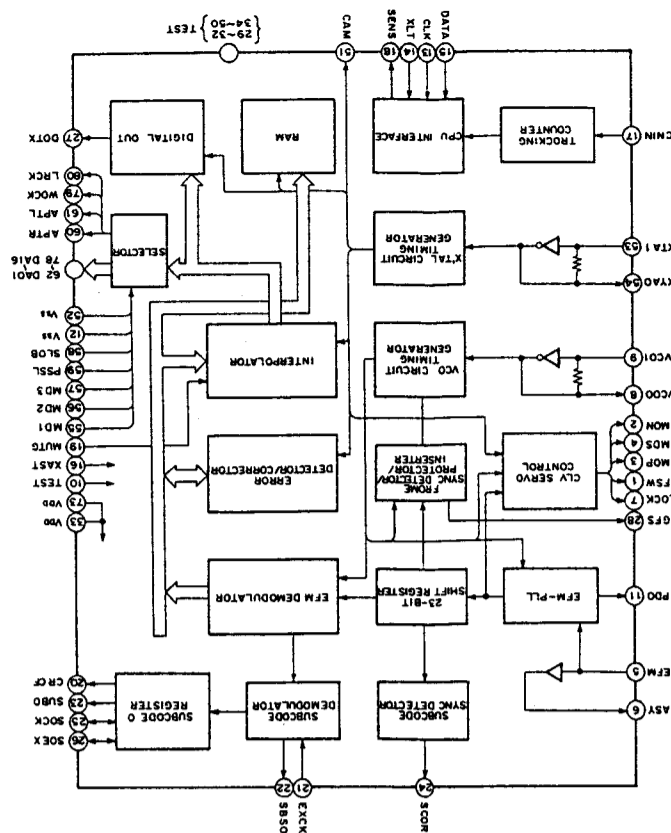

CXD11650

4.3 MECHANISM UNIT

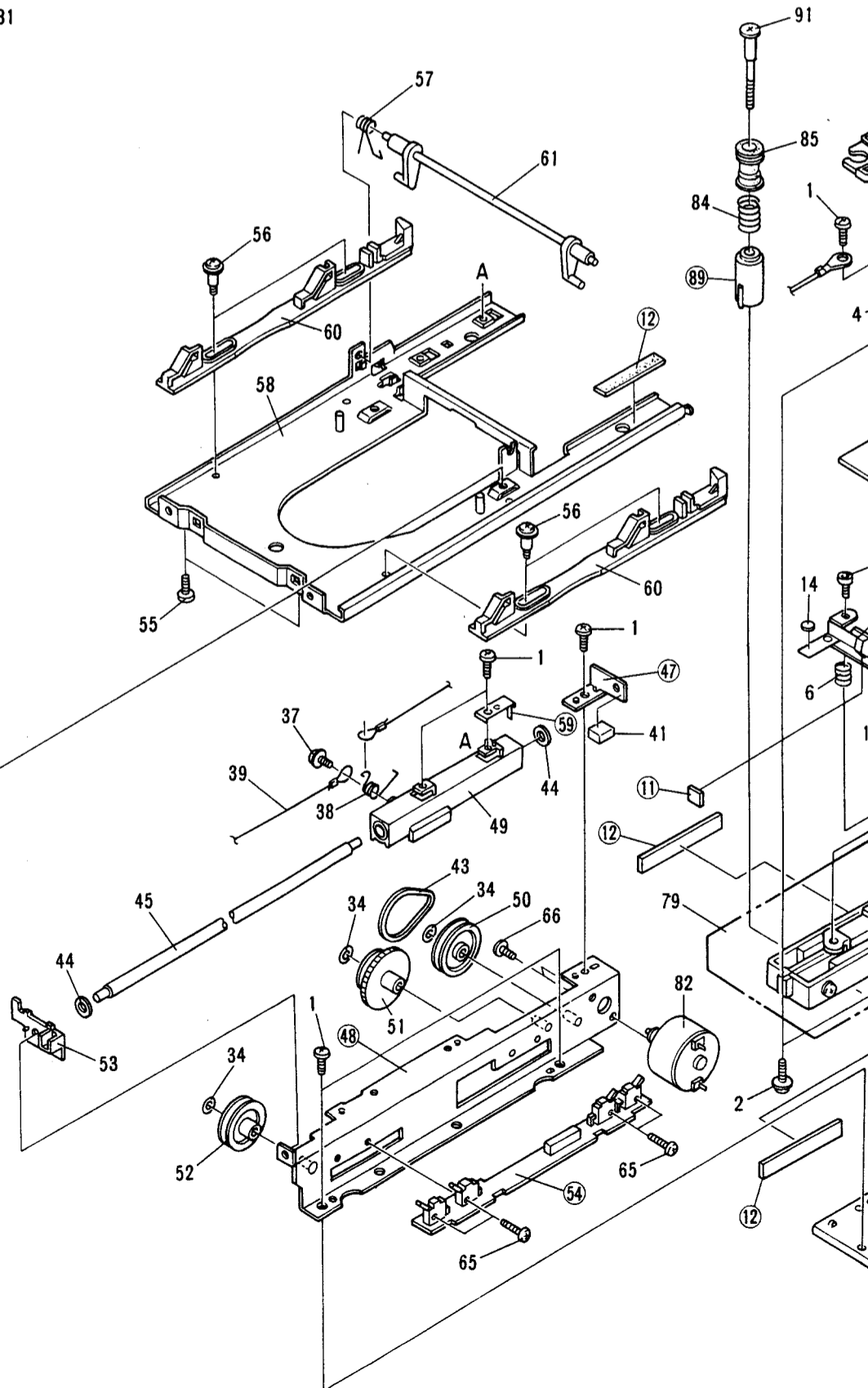
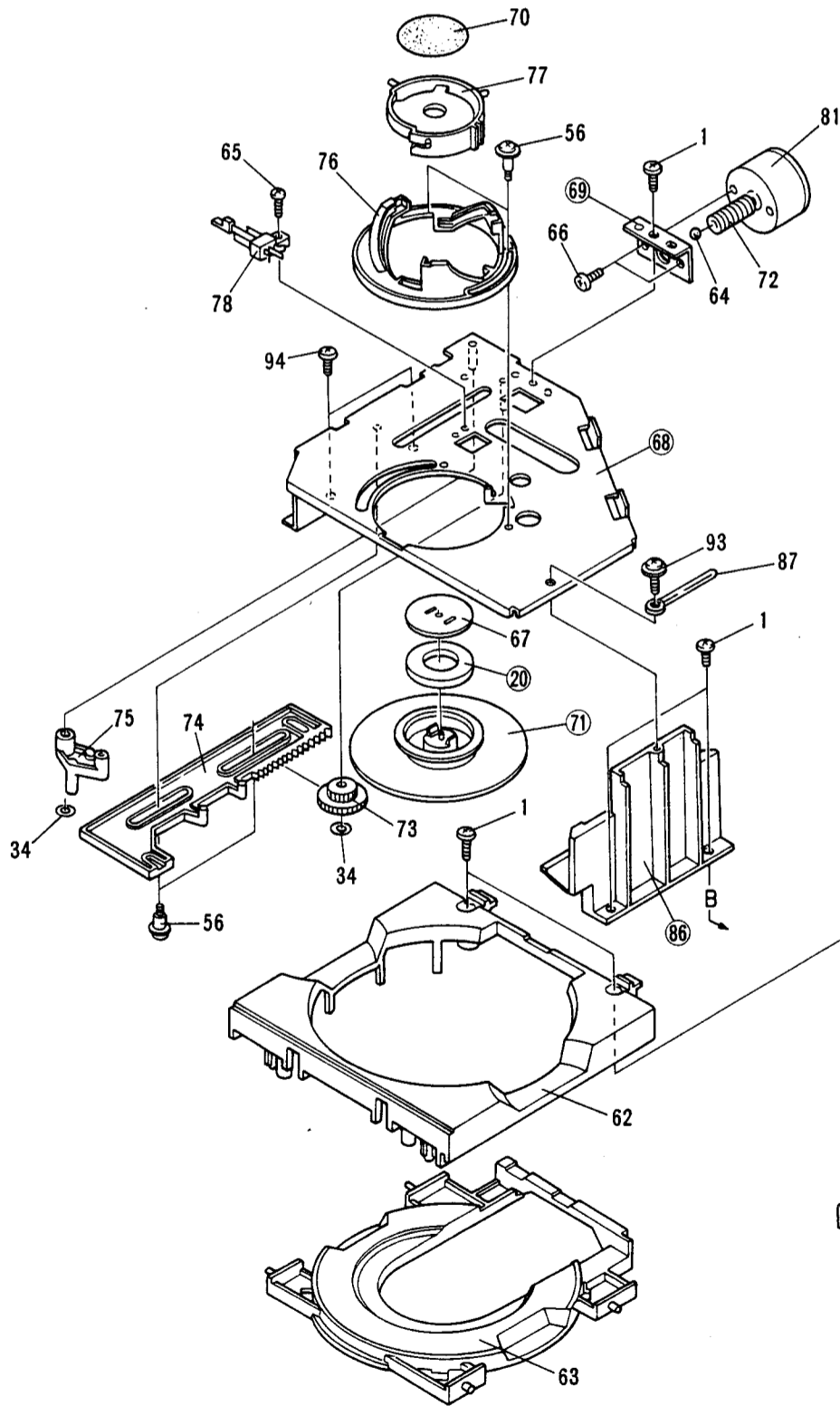

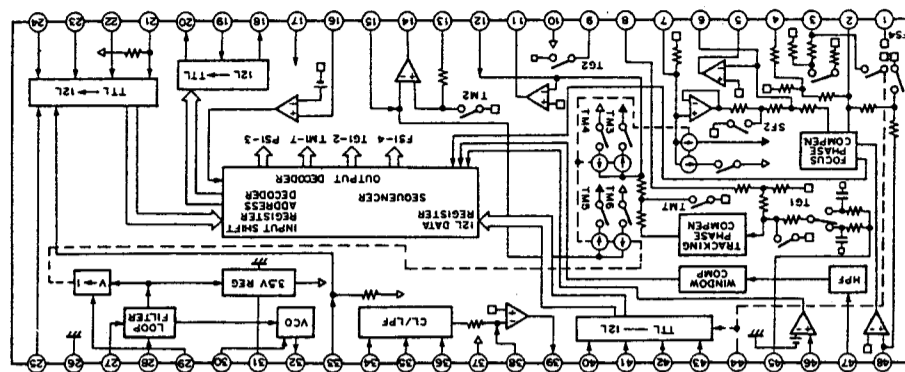
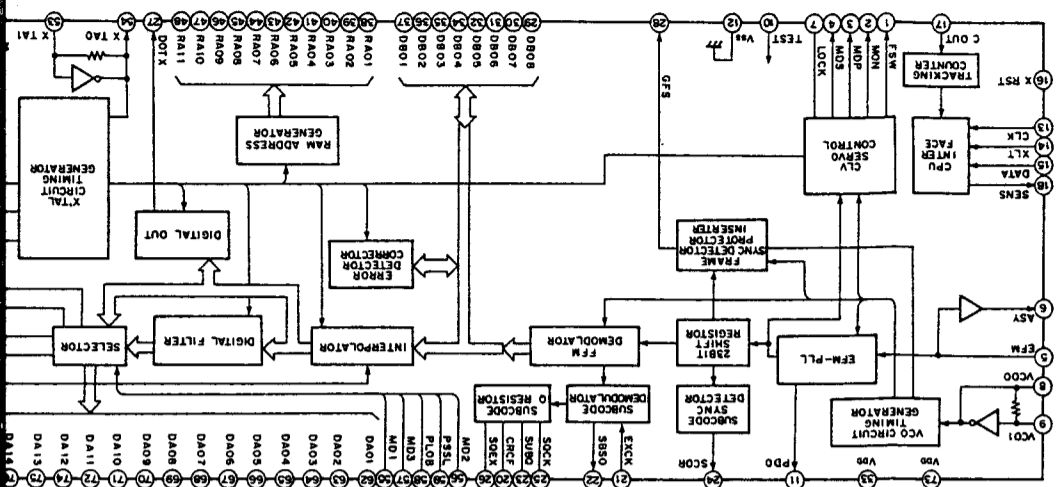

CXD11350Z

CXA1082AS

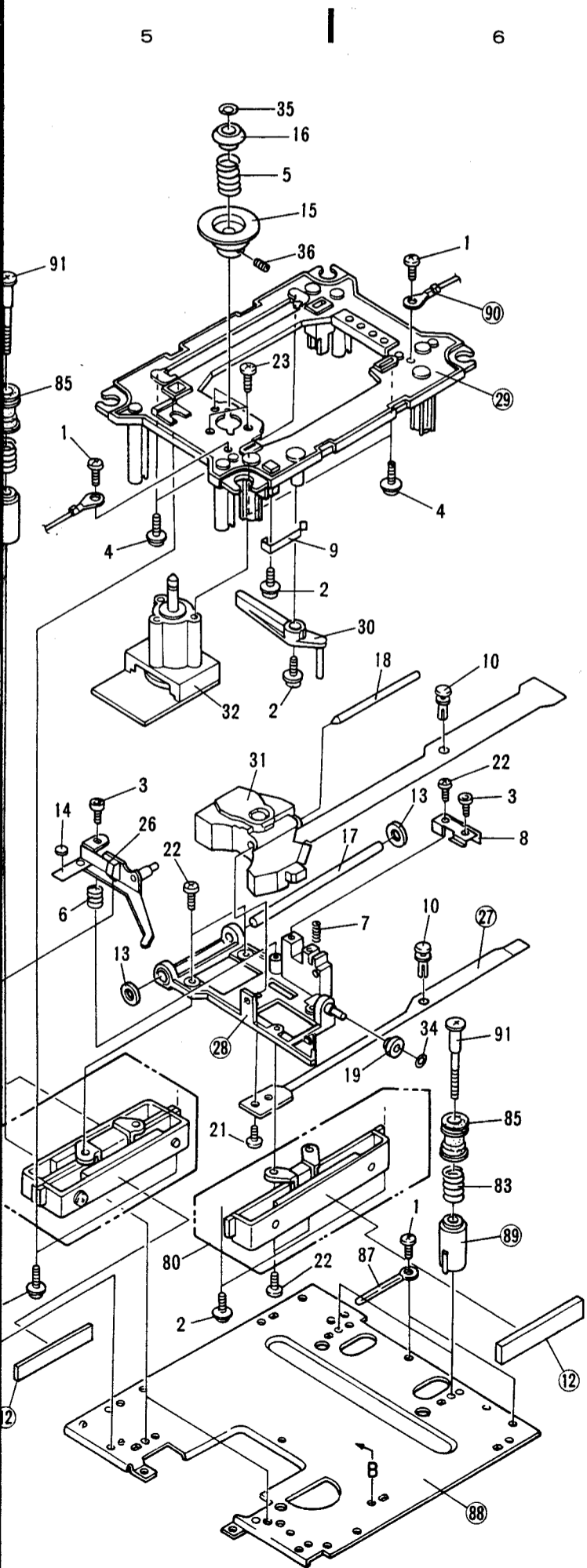

## 5. LINE VOLTAGE SELECTION

- A Line voltage can be changed with the following steps.
1. Disconnect the AC power cord.
  2. Remove the top cover.
  3. Change the transformer S (24VA) wire of terminal CN(A) - ① and CN(A) - ② as follows.

Voltage	Terminal No. CN(A) - ①	Terminal No. CN(A) - ②
220V	BLUE	PURPLE
240V	PURPLE	BLUE

Change the transformer A (13VA) wire of terminal CN(B) - ① and CN(B) - ② as follows.

B

Voltage	Terminal No. CN(B) - ①	Terminal No. CN(B) - ②
220V	BLUE	PURPLE
240V	PURPLE	BLUE

4. Stick the line voltage label on the rear panel.

Part No.	Description
AAX-193	220V label
AAX-192	240V label

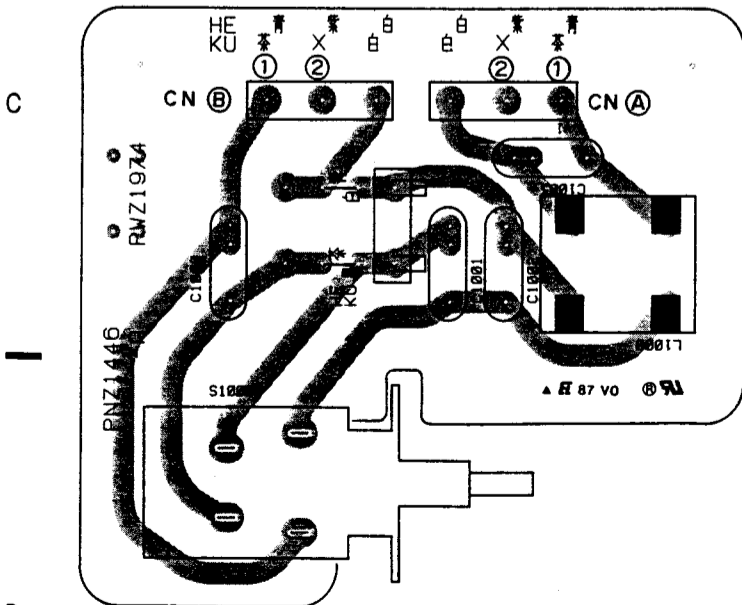

D PRIMARY BOARD ASSEMBLY

# 6. SCHEMATIC AND P.C. BOARDS CONNECTION DIAGRAMS

## 6.1 SCHEMATIC DIAGRAMS AND P.C. BOARDS OF RESPECTIVE ASSEMBLIES FOR MAIN BOARD, LOADING BOARD, MAIN AND SUB OPERATION BOARDS, LED BOARD

A

B

C

D

E

F

IC3 (System micro computer) P03154

Pin No.	Voltage	Pin No.	Voltage	Pin No.	Voltage
1	0	17	0	33	5.0
2	2.4	18	5.0	34	5.0
3	5.0	19	5.0	35	0
4	5.0	20	0	36	5.0
5	5.0	21	0	37	5.0
6	5.0	22	0	38	5.0
7	5.5	23	0	39	0
8	0	24	0	40	0
9	5.0	25	0	41	0.3 to 0.4
10	5.0	26	0	42	0
11	5.0	27	0	43	0
12	1.3 to 1.9	28	0	44	0
13	5.0	29	5.0	45	0.021
14	5.0	30	5.0	46	0.021
15	0	31	0	47	0
16	5.0	32	0	48	5.0

IC401 PDG036

Measure the voltages at Pins 33 to 46 at first program ('000') in the

Pin No.	Voltage	Pin No.	Voltage	Pin No.	Voltage
1	0.3 to 0.4	17	5.0	33	1.3
2	0	18	5.0	34	4.9
3	4.9	19	5.0	35	4.9
4	4.9	20	5.0	36	1.3
5	4.1	21	5.0	37	1.3
6	0	22	5.0	38	5.0
7	0.3 to 0.4	23	5.0	39	-24.4
8	0	24	0	40	-21.3
9	0	25	0	41	5.0
10	0	26	0	42	0.6
11	0	27	0	43	5.0
12	0	28	5.0	44	-24.4
13	0	29	5.0	45	1.8
14	0	30	0.01	46	-23.8
15	0	31	0.02	47	-20.9
16	5.0	32	0	48	-20.9

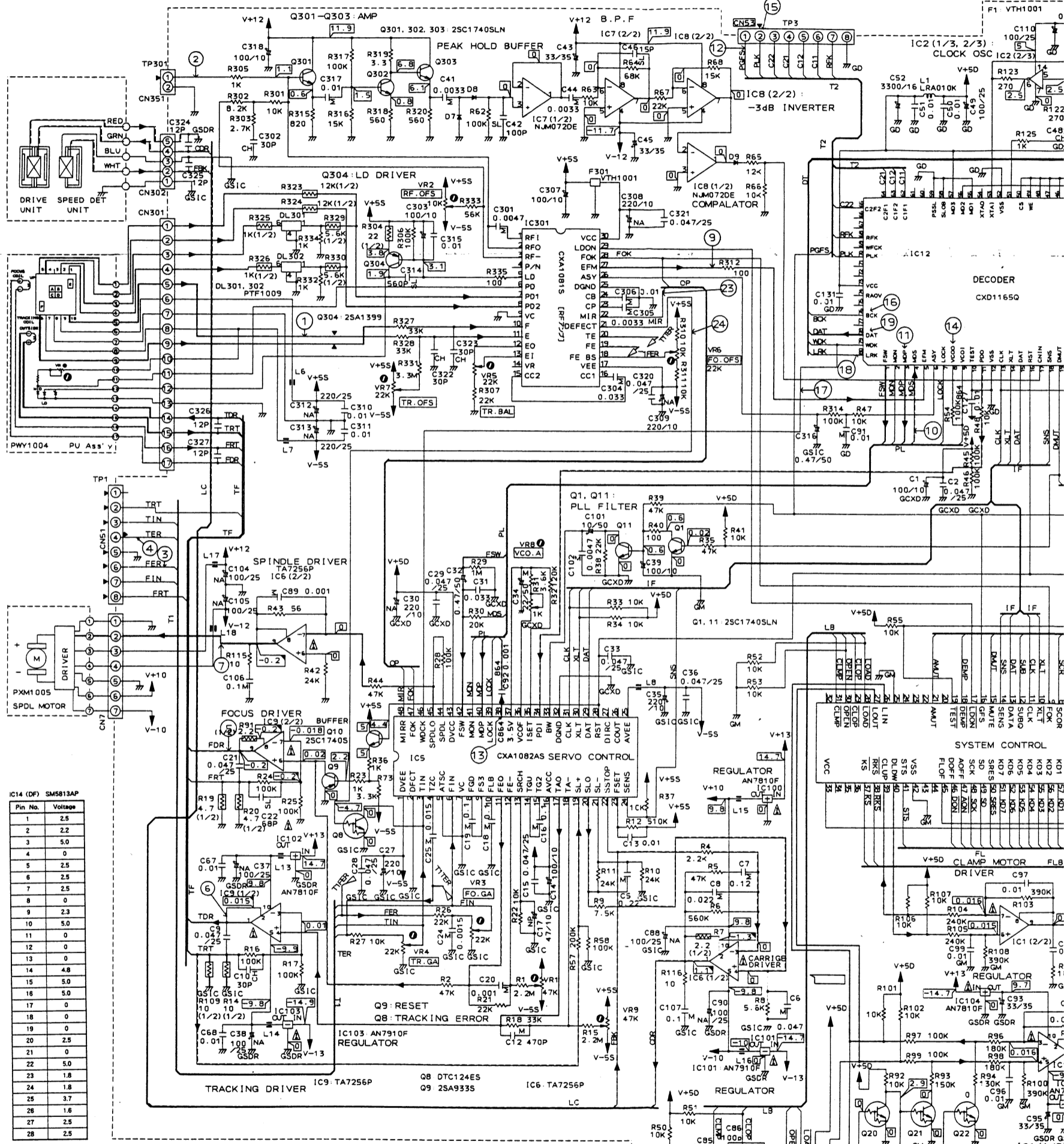

IC14 (DF) SM5813AP

Pin No.	Voltage
1	2.5
2	2.2
3	5.0
4	0
5	2.5
6	2.5
7	2.5
8	0
9	2.3
10	5.0
11	0
12	0
13	0
14	4.8
15	5.0
16	5.0
17	0
18	0
19	0
20	2.5
21	0
22	5.0
23	1.8
24	1.8
25	3.7
26	1.6
27	2.5
28	2.5

- Diodes not designated are 1SS254
- means
- RF reading ~ audio line
- Focus servo line
- Tracking servo line
- Carriage servo line
- Spindle servo line
- EFM-PLL servo line
- Loading motor route
- Clamp motor route

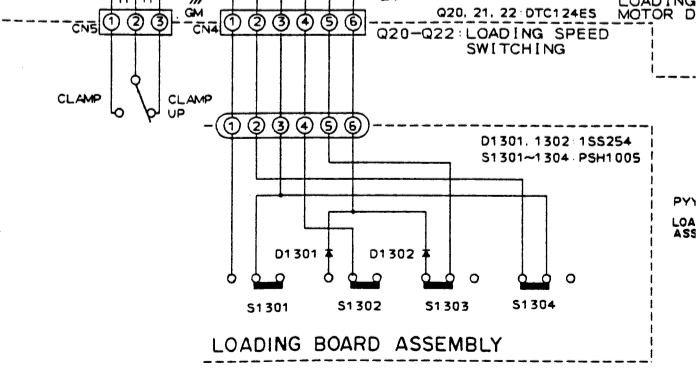
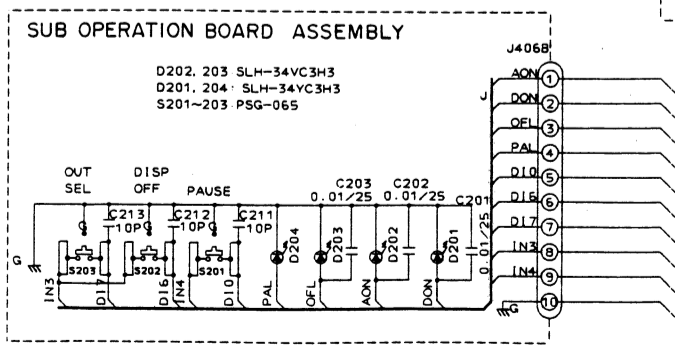

Program (000) in the cassette mode.

IC301 CXA10815

Voltage	Pin No.	Voltage
1.3	48	-20.9
4.9	50	-20.9
4.9	51	-20.9
1.3	52	-20.9
1.3	53	-20.9
5.0	54	-20.9
-24.4	55	-20.5
-21.3	56	-20.5
5.0	57	-24.3
0.6	58	0
5.0	59	0
-24.4	60	2.3
1.8	61	2.2
-23.8	62	5.0
-20.9	63	5.0
-20.9	64	5.0

Pin No.	Voltage	Pin No.	Voltage
1	0	16	-3
2	1.3	17	-5
3	0	18	0
4	2.4	19	0
5	2.8	20	0
6	-4.8	21	-4.9
7	0	22	0
8	0	23	-1
9	0	24	-2.1
10	0	25	0
11	0	26	2.5
12	-1.2	27	2.4
13	-0.1	28	5
14	0	29	0
15	-3.1	30	5

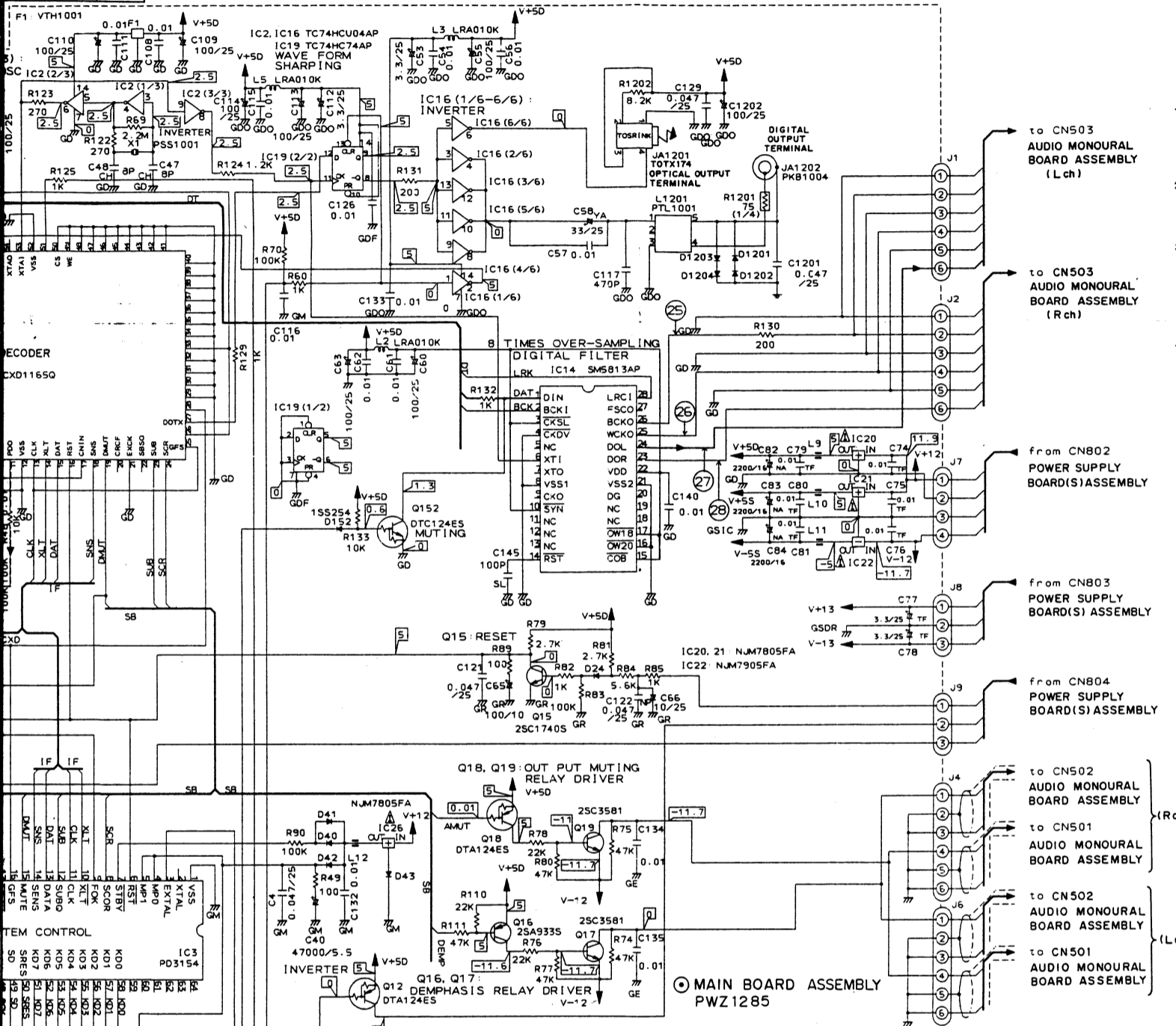

- RESISTORS**  
Unit : Ω, k, M, unless otherwise noted.  
Specified power : 1/4W, 1/8W, 1/2W unless otherwise noted.  
Tolerance : ±5%, (F): ±1%, (G): ±2%, (K): ±10%, (M): ±20% unless otherwise noted.
- CAPACITORS**  
Unit : μ, p, unless otherwise noted.  
Indication : Capacitor value/Pressure, The pressure not designated is 50V. (except electrical capacitor)
- VOLTAGE - CURRENT**  
⊖ : DC voltage (V) during playback  
⊖ : DC current during playback  
⊖ : DC voltage (V)\*  
\* Measurement value is varied.  
Value in parentheses ( ) is DC current in the stop mode.
- OTHERS**  
⊕ : Signal route  
⊙ : Adjusting point  
The ⊥ mark found on some component parts indicates the importance of the safety factor of the part. Therefore, when replacing, be sure to use parts of identical designation.  
\* marked capacitors and resistors have parts numbers.
- SWITCH (Under line indicates switch position)**  
Main operation board  
S401: PLAY  
S402: O/C  
S403: STOP  
S406: TRK FF  
S407: TRK REV  
Sub operation board  
S201: PAUSE  
S202: DISP OFF  
S203: OUT SEL  
Loading board  
S1301, S1302, S1303, S1304  
: Loading position switch  
Power supply board (S)  
S800: TEST  
S801: CRG FWD  
S802: CRG REV  
Primary board  
S1000: Power ON-OFF

IC12 (S-RAM built-in) CXD1165Q

Pin No.	Voltage	Pin No.	Voltage	Pin No.	Voltage
1	2.5	31	1.9	61	1.3
2	5	32	1.9	62	0
3	2.5	33	5	63	0
4	2.8	34	1.9	64	0
5	2.4	35	1.9	65	0
6	2.5	36	1.9	66	0
7	5	37	1.9	67	0
8	2.4	38	2.5	68	2.5
9	2.4	39	2.5	69	2.5
10	0	40	2.5	70	2.3
11	1.8	41	2.5	71	5
12	0	42	2.5	72	0
13	5	43	2.5	73	5
14	5	44	2.5	74	0
15	5	45	2.5	75	2.4
16	5	46	2.0 to 2.9	76	2.3
17	0	47	2.0 to 2.9	77	2.3
18	5	48	1.3 to 3.8	78	2.5
19	0	49	4.4	79	2.5
20	5	50	2.5	80	2.5
21	0	51	2.3		
22	0	52	0		
23	0	53	2.2		
24	0	54	2.2		
25	5	55	1.8		
26	5	56	0		
27	2.5	57	2.5		
28	5	58	0		
29	1.9	59	0		
30	1.9	60	1.3		

IC5 CXA1082S

Pin No.	Voltage	Pin No.	Voltage
1	-5	25	-5
2	0	26	0
3	0	27	5
4	0	28	5
5	0	29	5
6	0	30	5
7	0	31	5
8	0	32	0
9	0	33	2.5
10	0	34	2.5
11	-0.018 to 0.028	35	2.5
12	0	36	2.3
13	0.2	37	3.5
14	0	38	2.4
15	0	39	5
16	5	40	2.5
17	0	41	5
18	0	42	2.5
19	0	43	5
20	0	44	0
21	0	45	0.23 to 0.28
22	0	46	2.5
23	-4.1	47	5
24	5	48	0

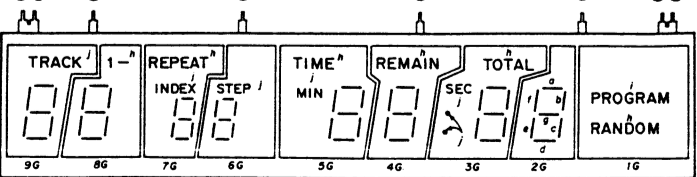
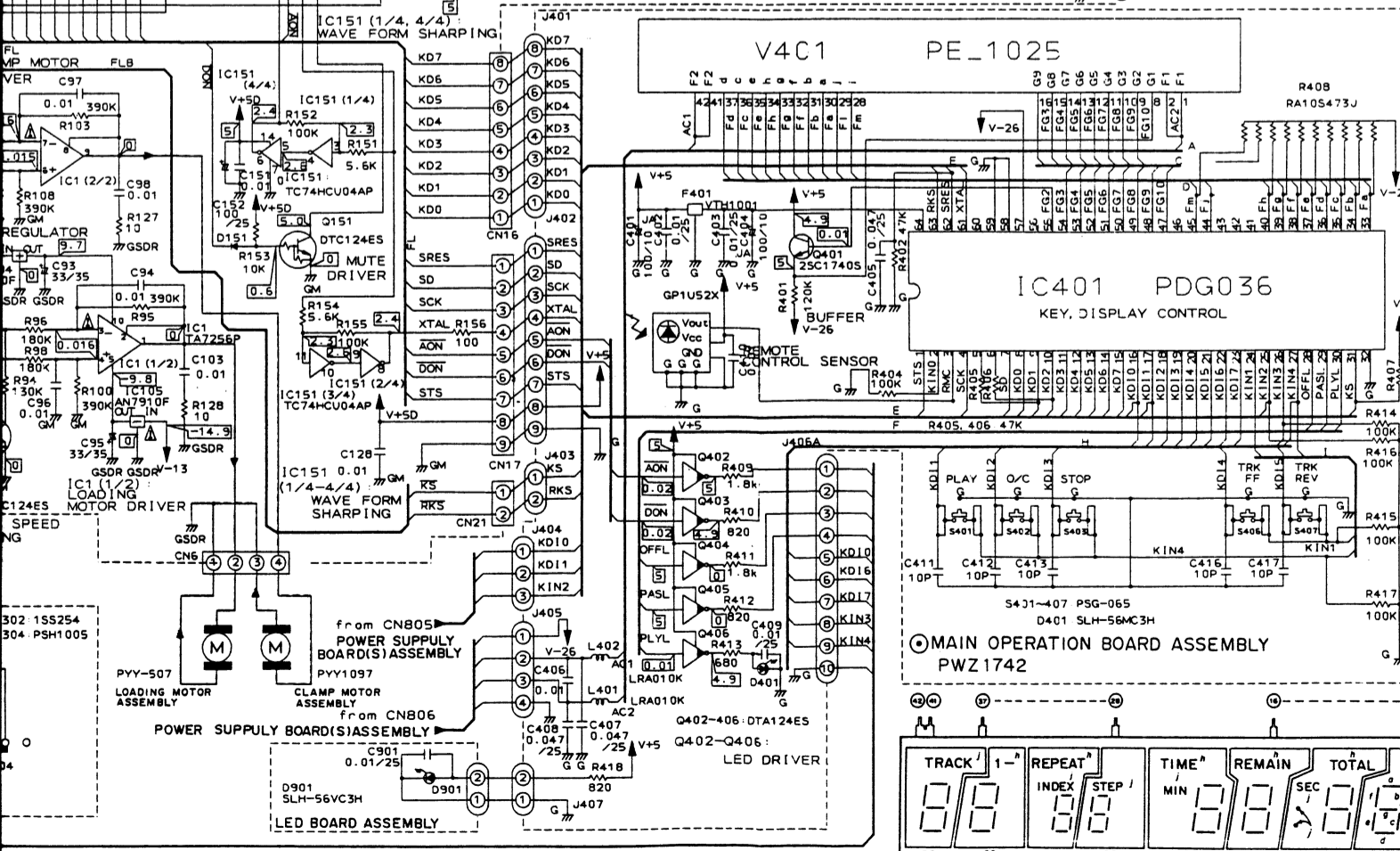

**PIN CONNECTION**

Pin No.	CONNECTION
1	2
2	2
3	2
4	2
5	2
6	2
7	2
8	2
9	2
10	2
11	2
12	2
13	2
14	2
15	2
16	2
17	2
18	2
19	2
20	2
21	2
22	2
23	2
24	2
25	2
26	2
27	2
28	2
29	2
30	2
31	2
32	2
33	2
34	2
35	2
36	2
37	2
38	2
39	2
40	2
41	2
42	2
43	2
44	2
45	2
46	2
47	2
48	2
49	2
50	2
51	2
52	2
53	2
54	2
55	2
56	2
57	2
58	2
59	2
60	2
61	2
62	2
63	2
64	2
65	2
66	2
67	2
68	2
69	2
70	2
71	2
72	2
73	2
74	2
75	2
76	2
77	2
78	2
79	2
80	2
81	2
82	2
83	2
84	2
85	2
86	2
87	2
88	2
89	2
90	2
91	2
92	2
93	2
94	2
95	2
96	2
97	2
98	2
99	2
100	2



MAIN BOARD ASSEMBLY (PWM1285)

TO AUDIO MONOURAL BOARD ASSEMBLY CN503(Rch)  
TO AUDIO MONOURAL BOARD ASSEMBLY CN503(Lch)

MAIN OF

TO POWER SUPPLY BOARD(S) ASSEMBLY CN806  
TO POWER SUPPLY BOARD(S) ASSEMBLY CN805

SUB OPERATION

A

IC19  
IC16 IC51  
102 Q152  
IC14 Q16  
IC12 IC18

DEGTAL OUTPUT TERMINAL

OPTICAL OUTPUT TERMINAL

B

IC20 IC26 IC3  
IC8 Q1  
IC7 Q15 Q151  
Q11 Q20,Q21  
Q17, Q19 Q12  
Q10 Q22  
IC101 IC105

VR8

C

IC5  
IC103,IC102  
Q8 Q9 IC9

VR9, VR1  
VR4

VR3

VR6

VR7

VR5

VR2

D

Q304  
IC21, IC22  
Q301  
Q303  
Q302

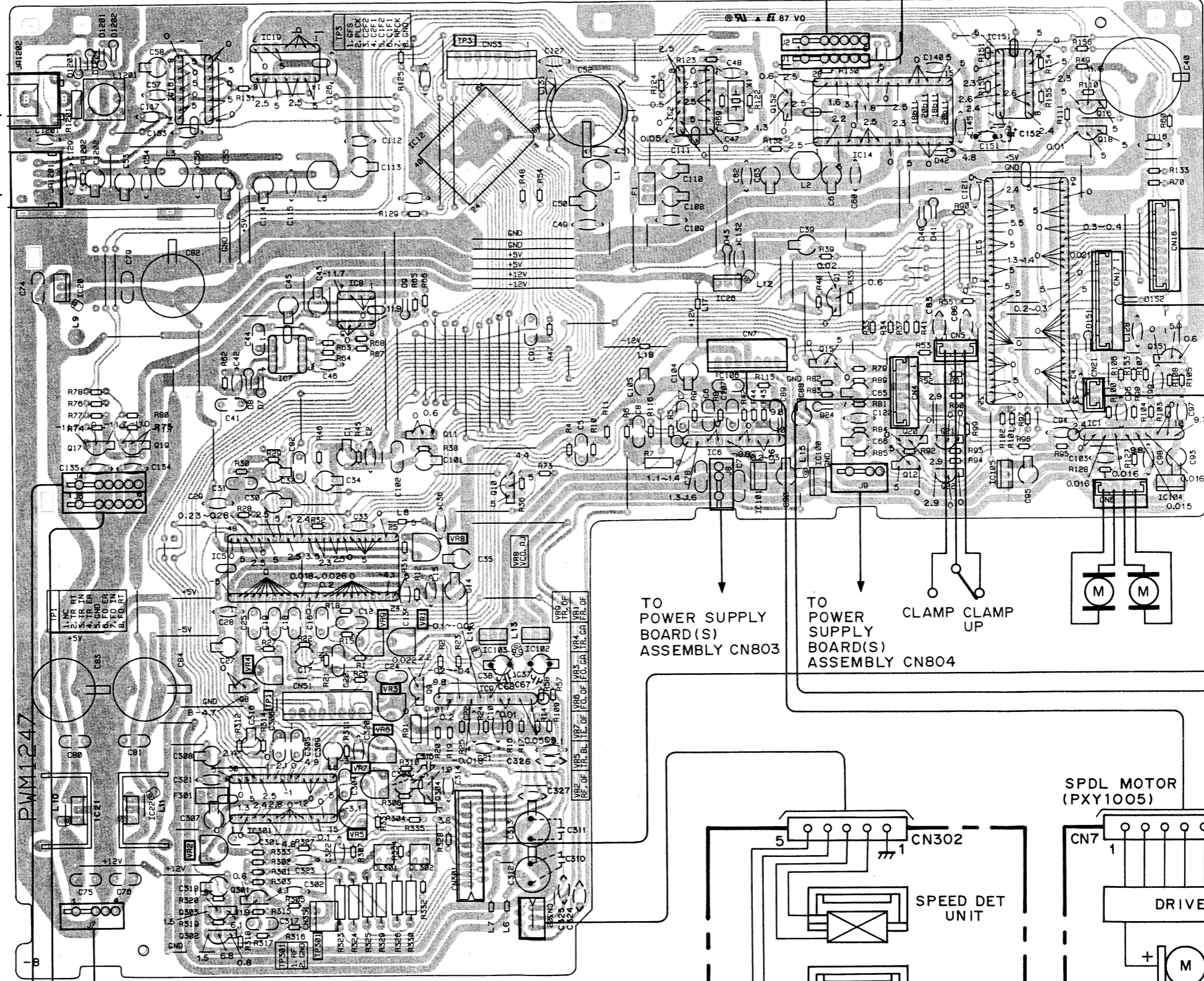

TO POWER SUPPLY BOARD(S) ASSEMBLY CN803

TO POWER SUPPLY BOARD(S) ASSEMBLY CN804

CLAMP CLAMP UP

SPDL MOTOR (PXY1005)

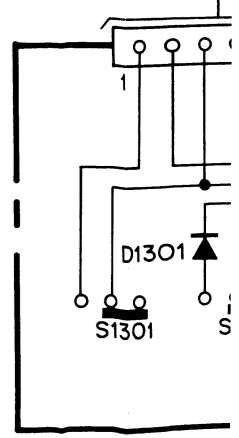
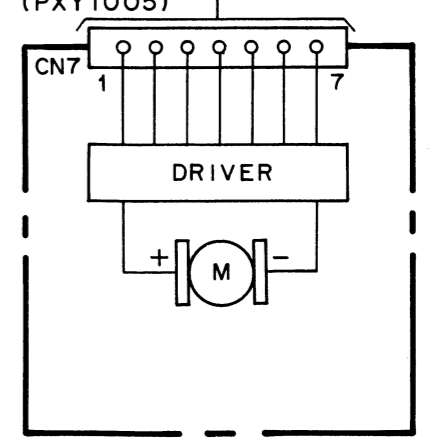
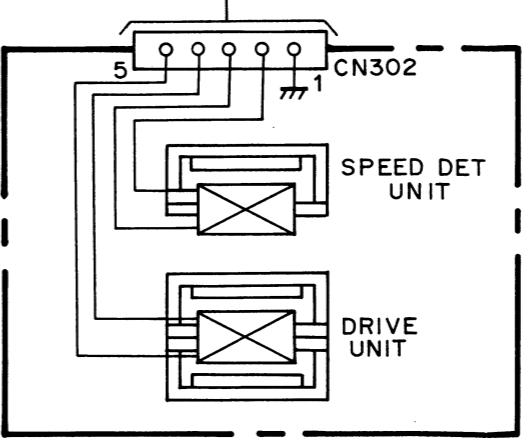

TO POWER SUPPLY BOARD(S) ASSEMBLY CN802  
TO AUDIO MONOURAL BOARD ASSEMBLY CN501,502  
TO AUDIO MONOURAL BOARD ASSEMBLY CN501,502

MBLY CN503(Rch)  
 MBLV CN503(Lch) MAIN OPERATION BOARD ASSEMBLY (PWZ1742)

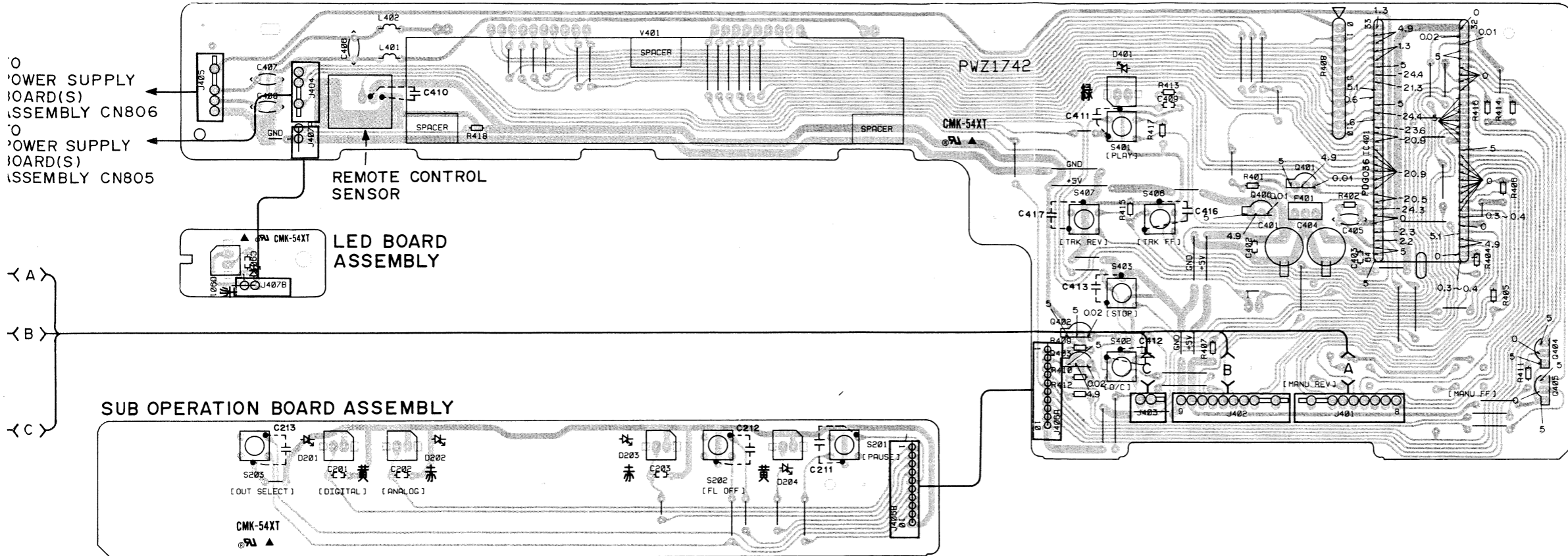

(A)  
 (B)  
 (C)

Note: (L9 to L16, L504, L700, L701, L800 and L801) are inserted to Pin of each semiconductor.

P.C.B. pattern diagram indication	Corresponding part symbol	Part name
		Transistor
		FET
		Diode
		Zener diode
		LED
		Varactor
		Tact switch
		Inductor
		Coil
		Transformer
		Filter
		Ceramic capacitor
		Mylar capacitor
		Styrol capacitor
		Electrolytic capacitor (Non polarized)
		Electrolytic capacitor (Noiseless)
		Electrolytic capacitor (Polarized)
		Electrolytic capacitor (Polarized)
		Power capacitor
		Semi-fixed resistor
		Resistor array
		Resistor
		Resonator
		Thermistor

IC12 (S-RAM built-in) CXD1165Q

Pin No.	Voltage	Pin No.	Voltage	Pin No.	Voltage
1	2.5	31	1.9	61	1.3
2	5	32	1.9	62	0
3	2.5	33	5	63	0
4	2.8	34	1.9	64	0
5	2.4	35	1.9	65	0
6	2.5	36	1.9	66	0
7	5	37	1.9	67	0
8	2.4	38	2.5	68	2.5
9	2.4	39	2.5	69	2.5
10	0	40	2.5	70	2.3
11	1.8	41	2.5	71	5
12	0	42	2.5	72	0
13	5	43	2.5	73	5
14	5	44	2.5	74	0
15	5	45	2.5	75	2.4
16	5	46	2.0 to 2.9	76	2.3
17	0	47	2.0 to 2.9	77	2.3
18	5	48	1.3 to 3.6	78	2.5
19	0	49	4.4	79	2.5
20	5	50	2.5	80	2.5
21	0	51	2.3		
22	0	52	0		
23	0	53	2.2		
24	0	54	2.2		
25	5	55	1.8		
26	5	56	0		
27	2.5	57	2.5		
28	5	58	0		
29	1.9	59	0		
30	1.9	60	1.3		

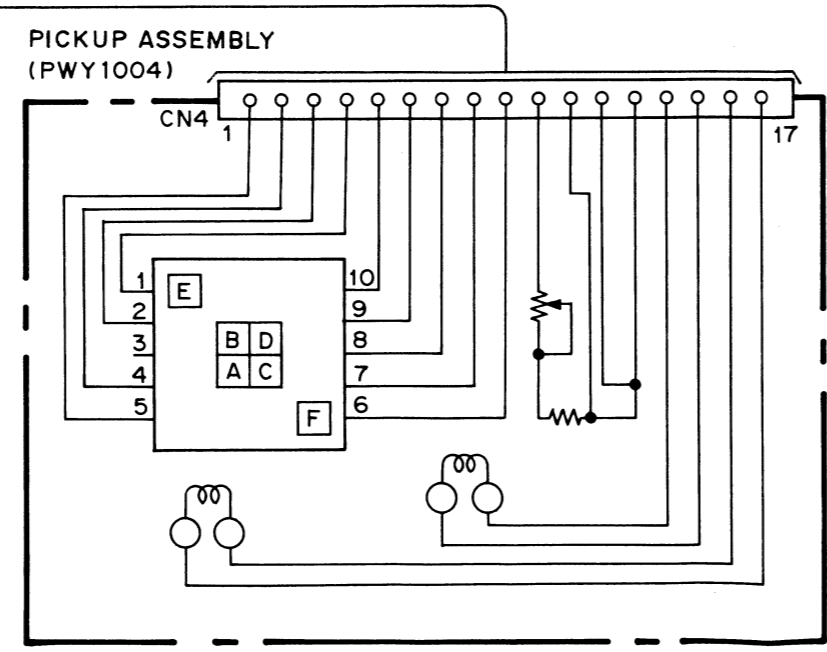
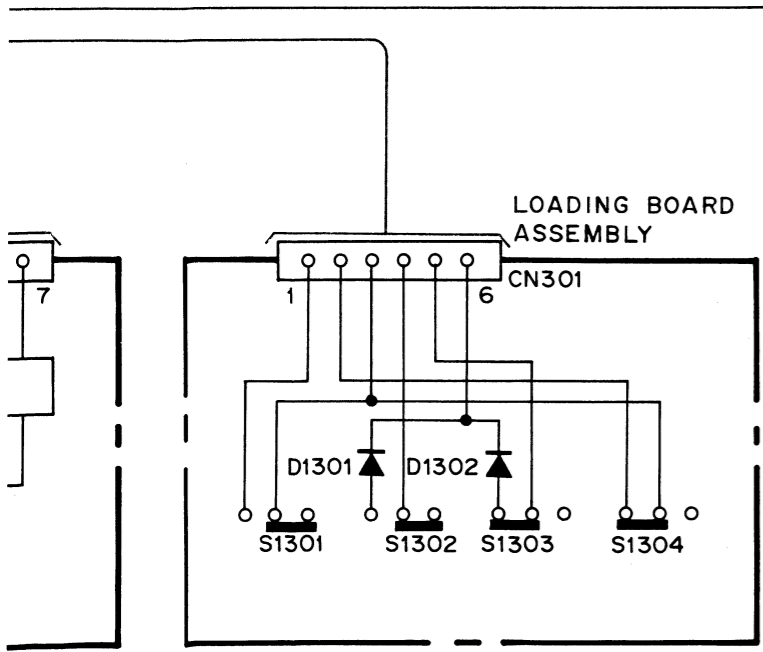

1. This P.C.B. connection diagram is viewed from the parts mounted side.  
 2. The parts which have been mounted on the board can be replaced with those shown with the corresponding wiring symbols listed in the above Table.  
 3. The capacitor terminal marked with shows negative terminal.  
 4. The diode marked with shows cathode side.  
 5. The transistor terminal marked with shows emitter.

A  
B  
C

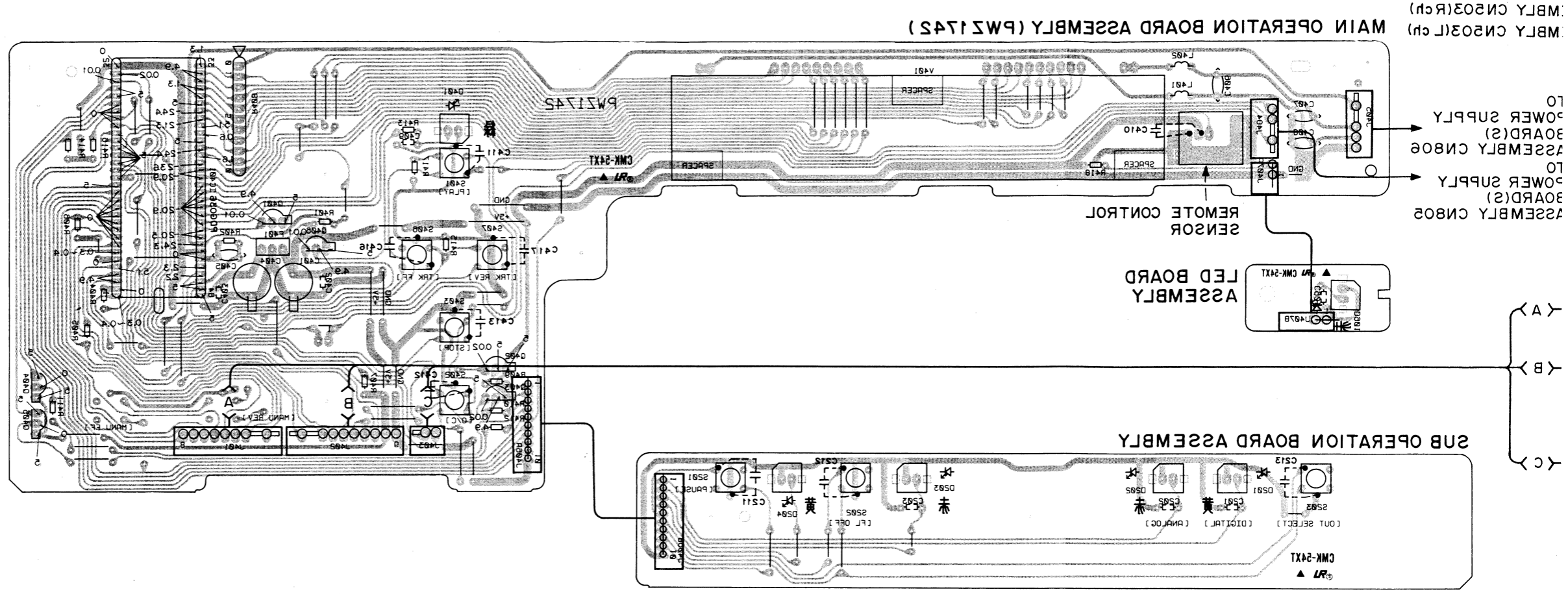

MAIN OPERATION BOARD ASSEMBLY (PWZ174S)  
M.BLY CN503(L ch)  
M.BLY CN503(R ch)  
POWER SUPPLY  
BOARD(S)  
ASSEMBLY CN805  
POWER SUPPLY  
BOARD(S)  
ASSEMBLY CN805

IC12 (2-RAM built-in) CKD1188D

Pin No.	Pin No.	Pin No.	Pin No.	Pin No.	Pin No.
1	52	31	19	81	13
2	5	32	19	82	0
3	52	33	52	83	0
4	58	34	19	84	0
5	54	35	19	85	0
6	52	36	19	86	0
7	5	37	19	87	0
8	54	38	52	88	52
9	54	39	52	89	52
10	0	40	52	90	52
11	18	41	52	91	2
12	0	42	52	92	0
13	52	43	52	93	2
14	52	44	52	94	0
15	52	45	52	95	54
16	52	46	5.0 to 5.9	96	5.3
17	52	47	5.0 to 5.9	97	5.3
18	52	48	1.3 to 3.9	98	52
19	0	49	44	99	52
20	52	50	52	100	52
21	52	51	52		
22	52	52	52		
23	52	53	52		
24	52	54	52		
25	18	55	52		
26	0	56	52		
27	52	57	52		
28	0	58	52		
29	19	59	52		
30	13	60	52		

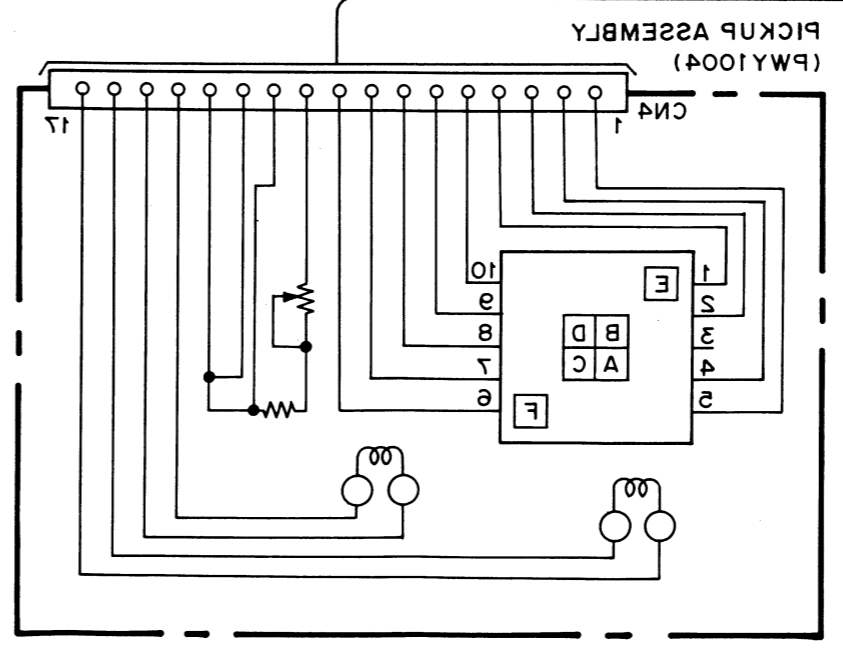
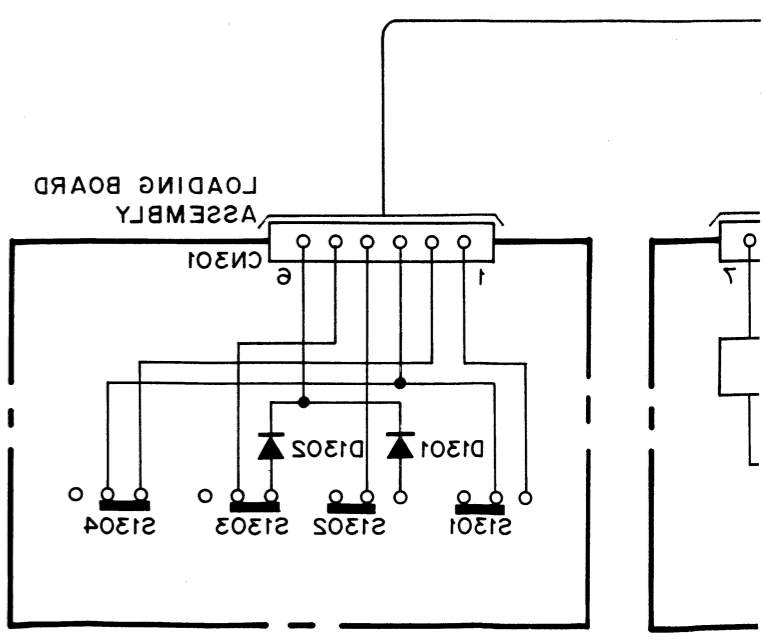

This P.C.B. connection diagram is viewed from the foil side.

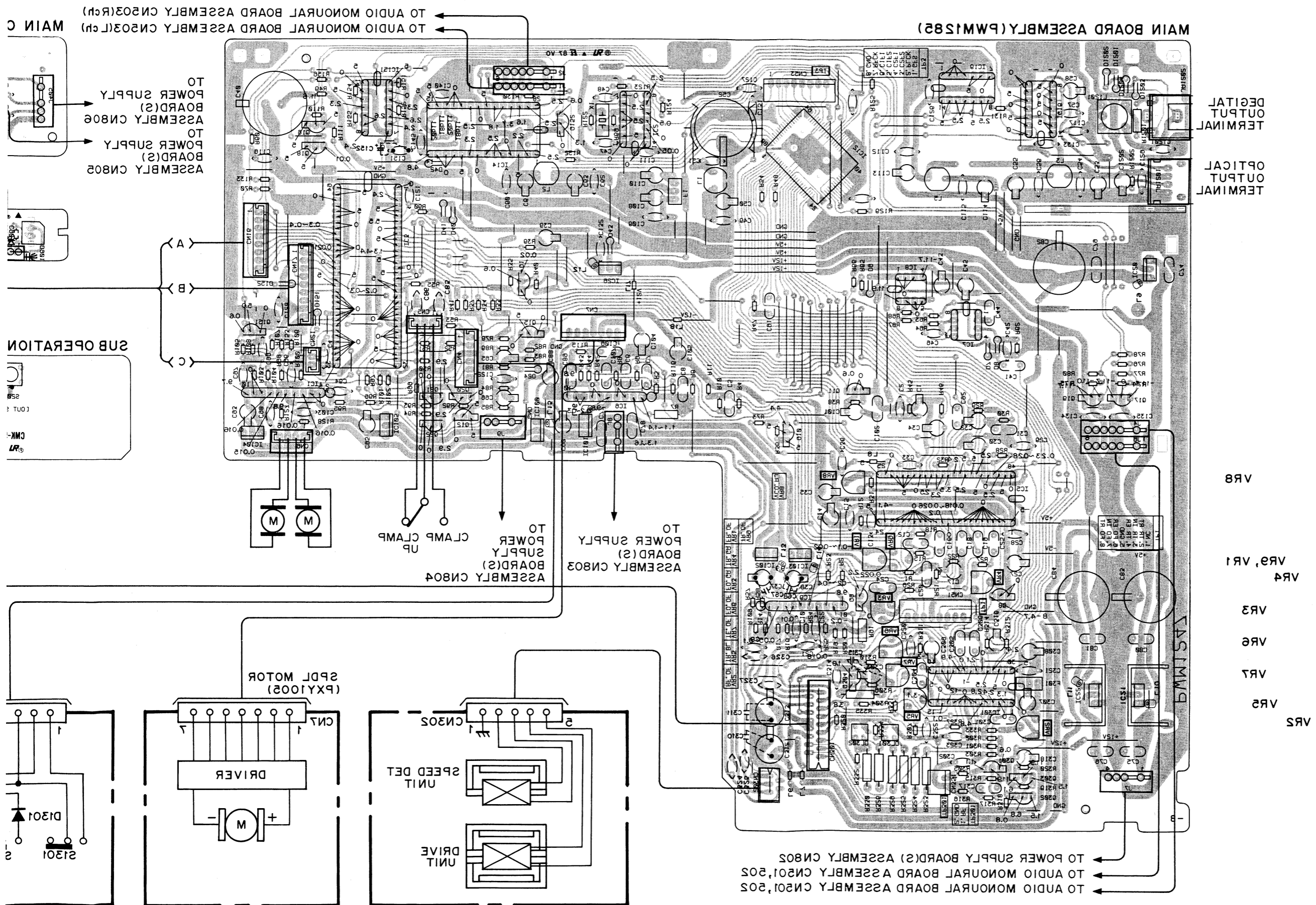

Terminal	Component
OPTICAL OUTPUT TERMINAL	IC15
DIGITAL OUTPUT TERMINAL	IC14, IC18, IC16, IC21
VR8	IC2
VR4, VR1	IC103, IC105
VR3	IC8, IC9
VR6	IC3
VR7	IC7
VR5	IC1, IC5, IC11, IC12, IC13, IC14, IC15, IC16, IC17, IC18, IC19, IC20, IC21
VR2	IC22, IC23, IC24, IC25, IC26, IC27, IC28, IC29, IC30, IC31, IC32, IC33, IC34, IC35, IC36, IC37, IC38, IC39, IC40, IC41, IC42, IC43, IC44, IC45, IC46, IC47, IC48, IC49, IC50

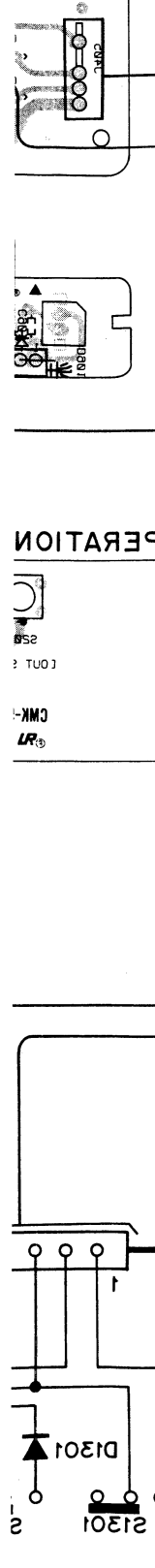

20V 60 Hz  
AC 150V (K\CA)  
250V (HEM)  
AC POWER CORD

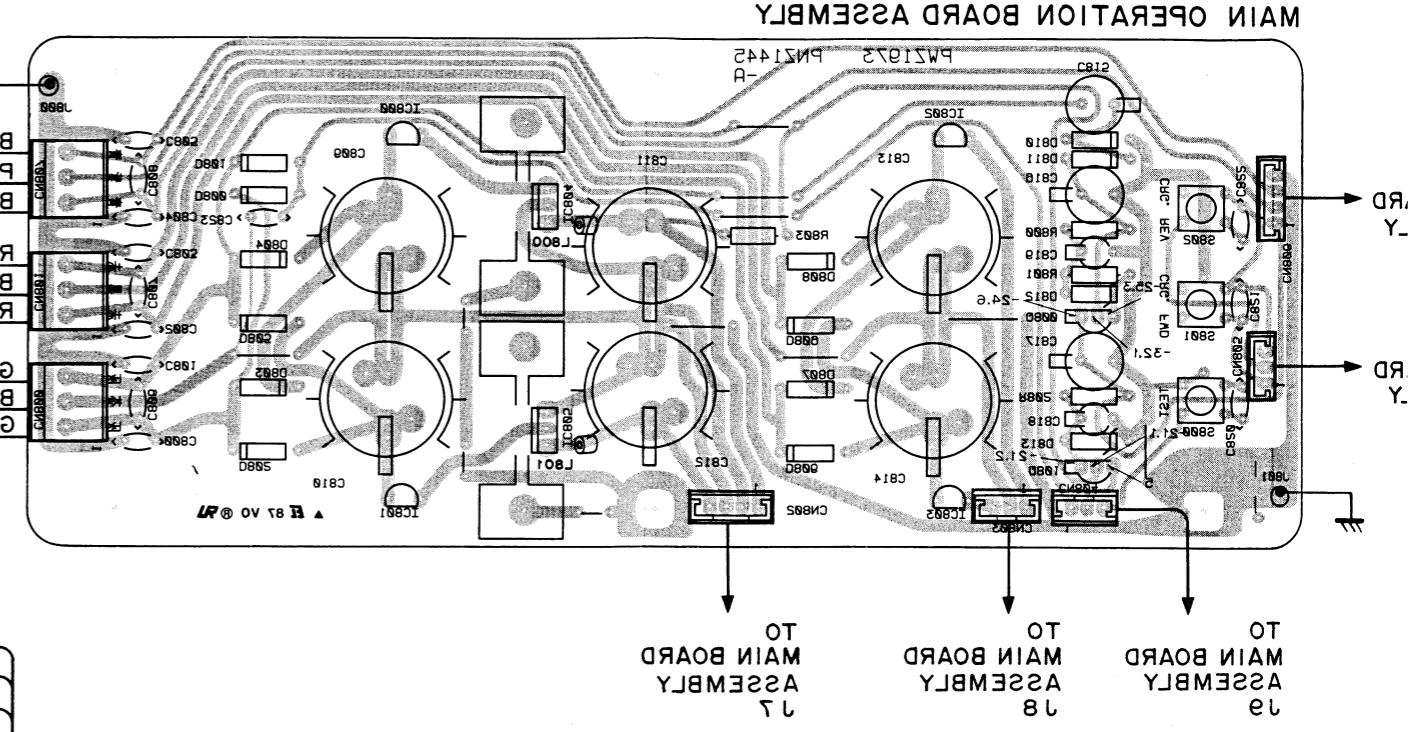
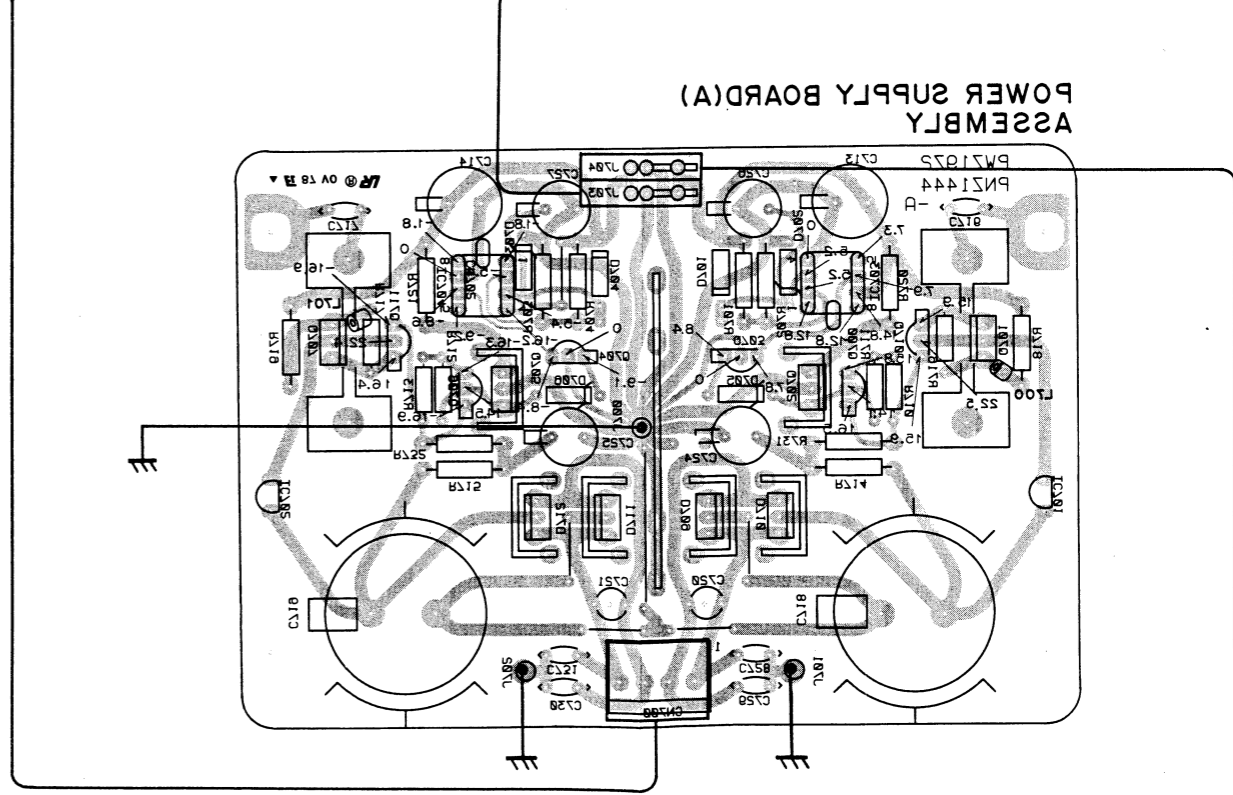
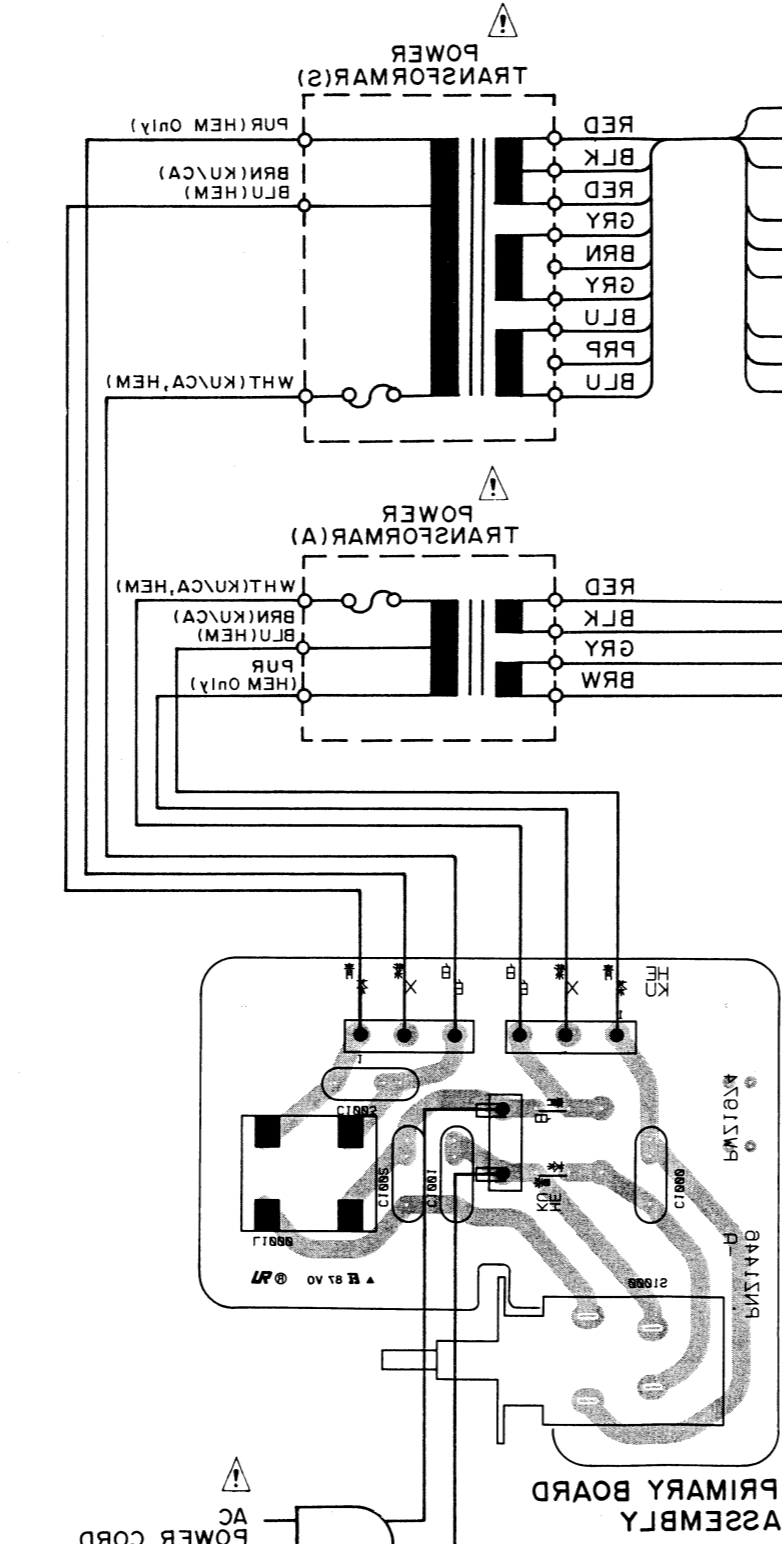

A  
B  
C  
D

MAIN OPERATION BOARD ASSEMBLY

TO MAIN BOARD ASSEMBLY 79  
TO MAIN BOARD ASSEMBLY 78  
TO MAIN BOARD ASSEMBLY 77

6.3 SCHEMATIC DIAGRAMS AND P.C. BOARDS OF RESPECTIVE ASSEMBLIES FOR AUDIO MONORAL BOARDS (Lch), (Rch), POWER SUPPLY BOARDS (A), (2) AND PRIMARY BOARD

This P.C.B. connection diagram is viewed from the foil side.

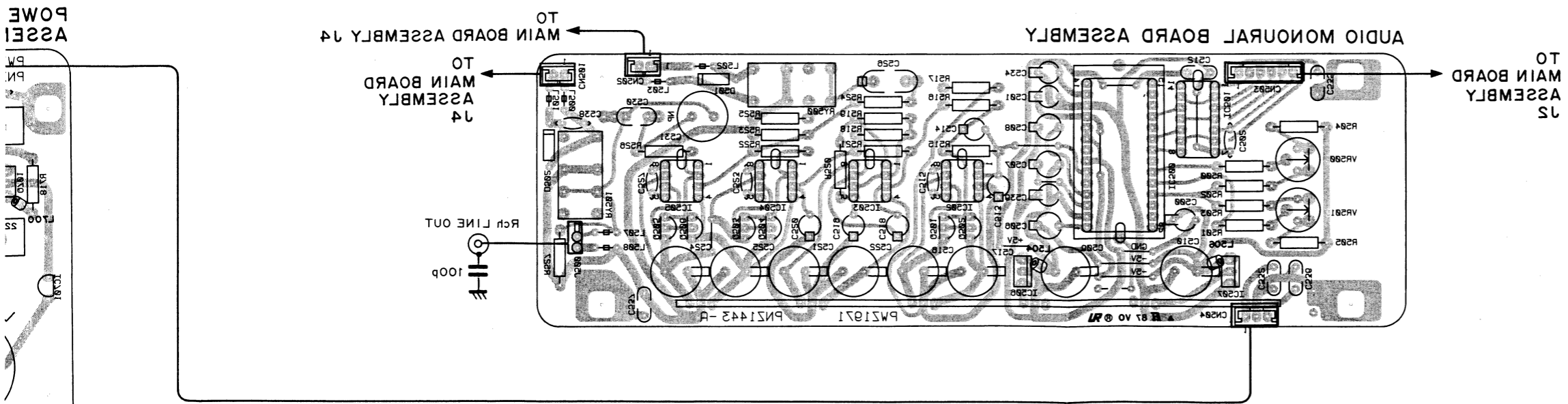
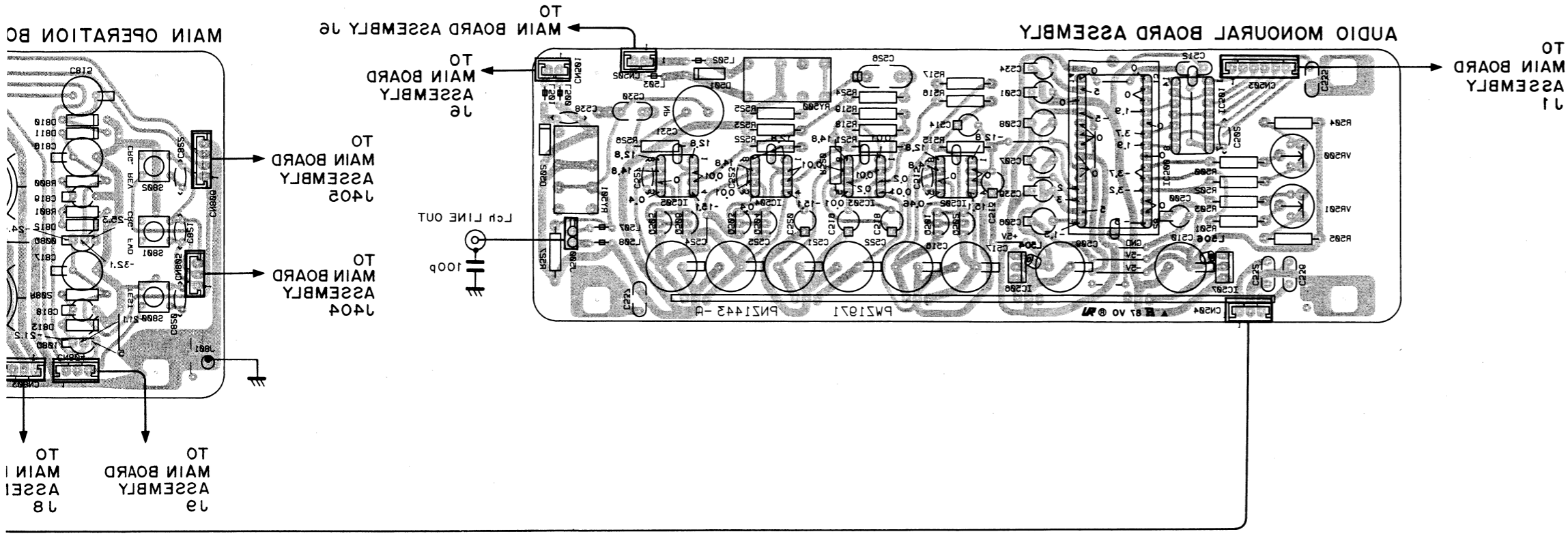

6.2 SCHEMATIC DIAGRAMS AND P.C. BOARDS OF RESPECTIVE ASSEMBLIES FOR AUDIO MONAURAL BOARDS (Lch), (Rch), POWER SUPPLY BOARDS (A), (S) AND PRIMARY BOARD

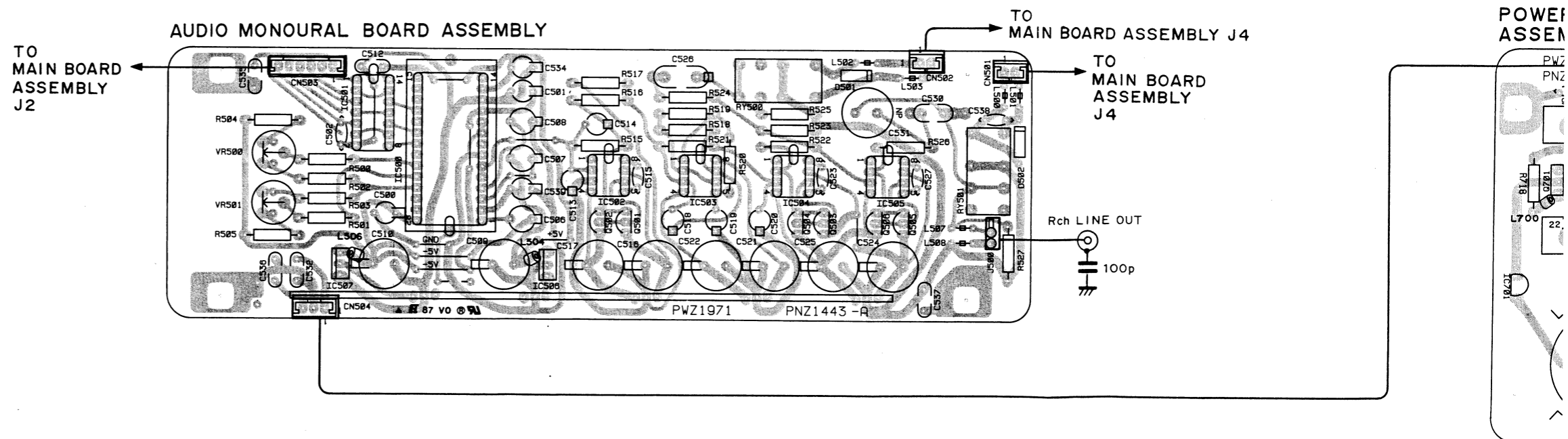
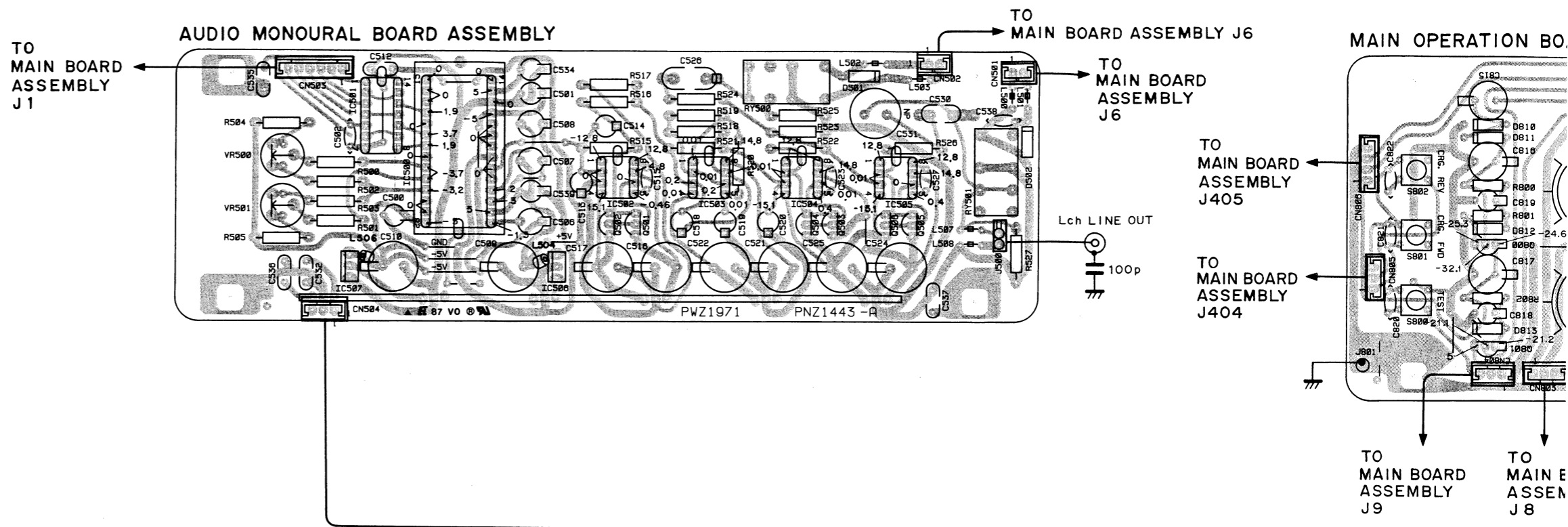

### MAIN OPERATION BOARD ASSEMBLY

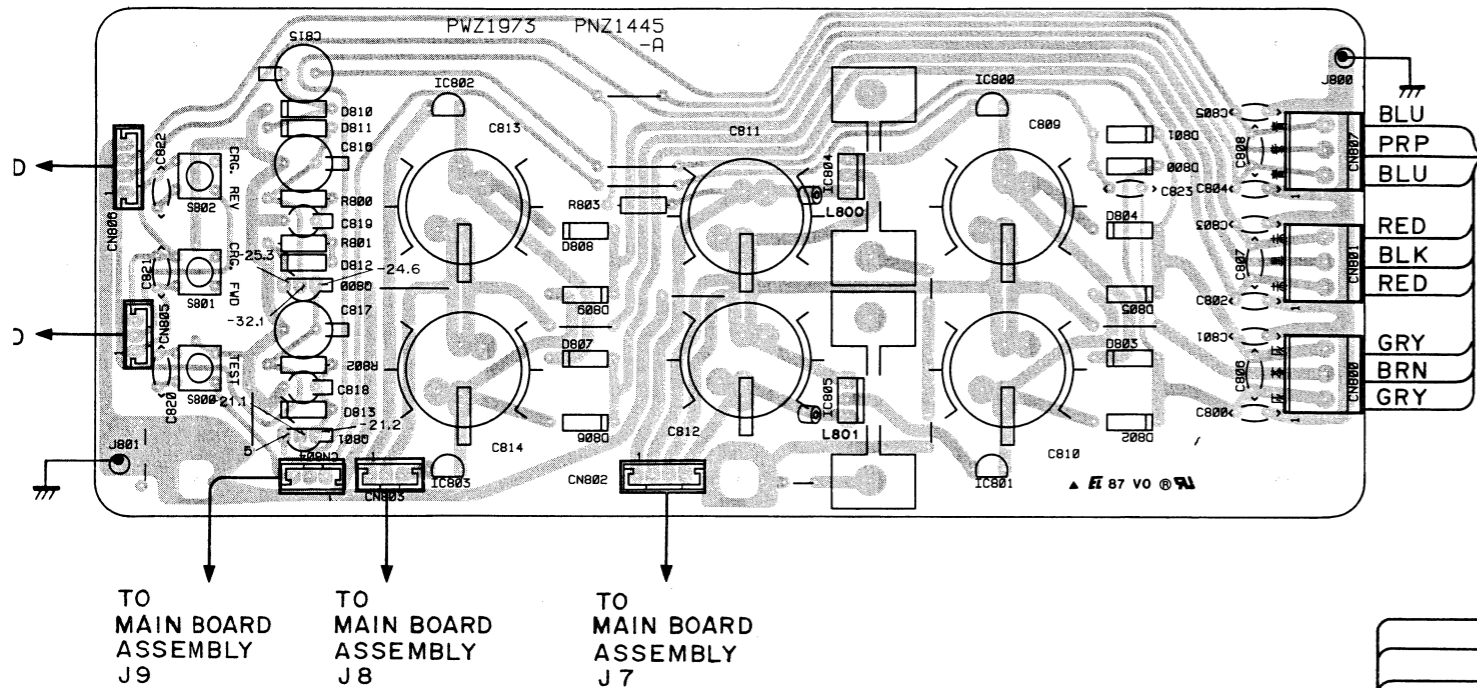

### POWER SUPPLY BOARD(A) ASSEMBLY

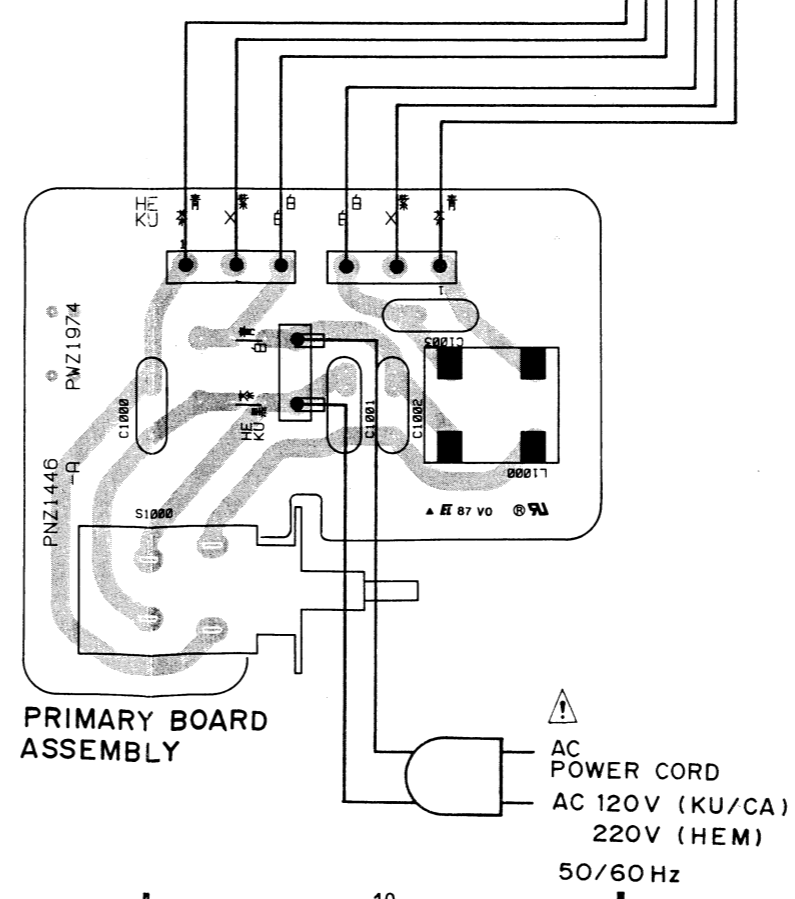
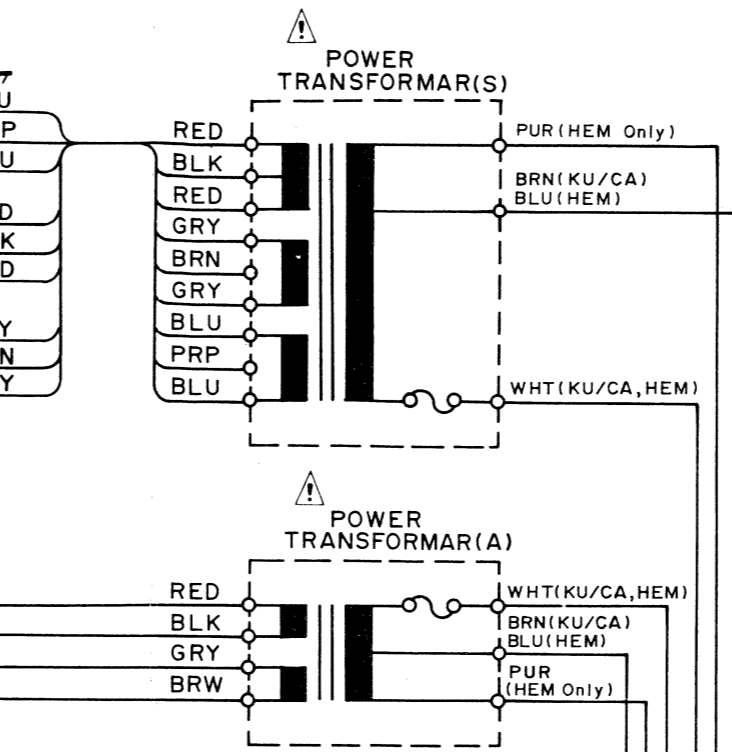
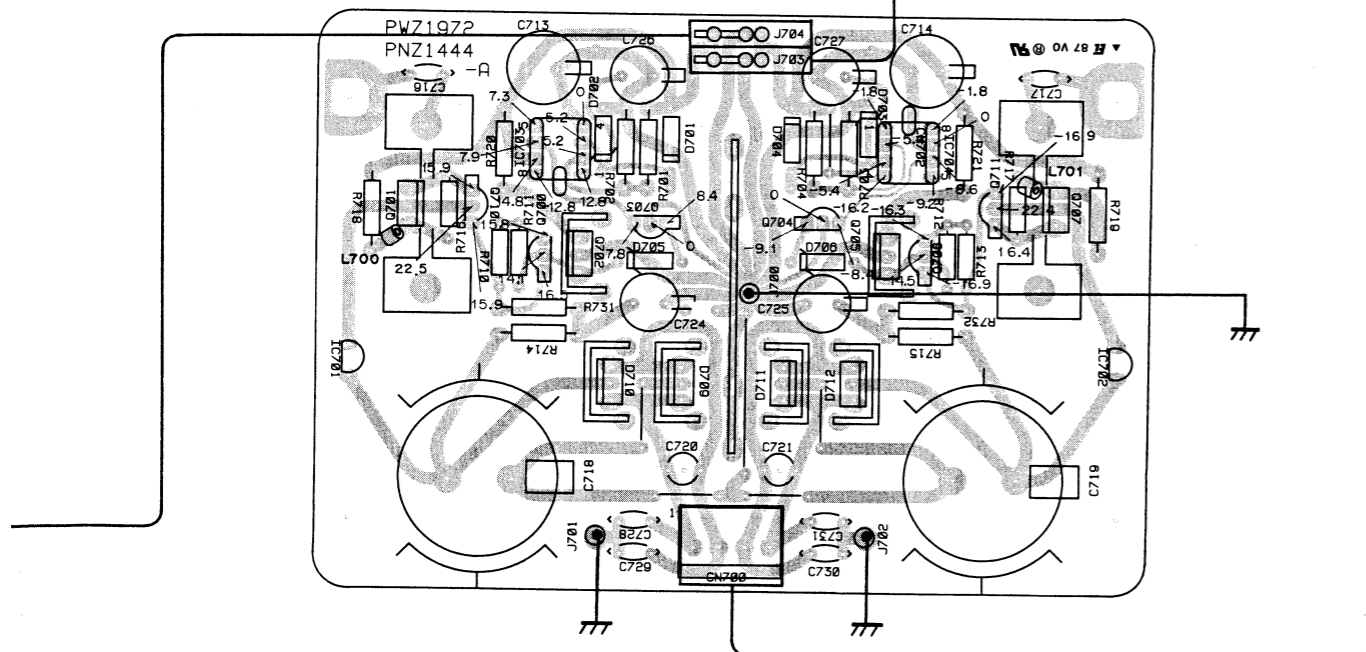

A

B

C

D



1 2 3 4 5 6

A

B

C

D

A

B

C

D

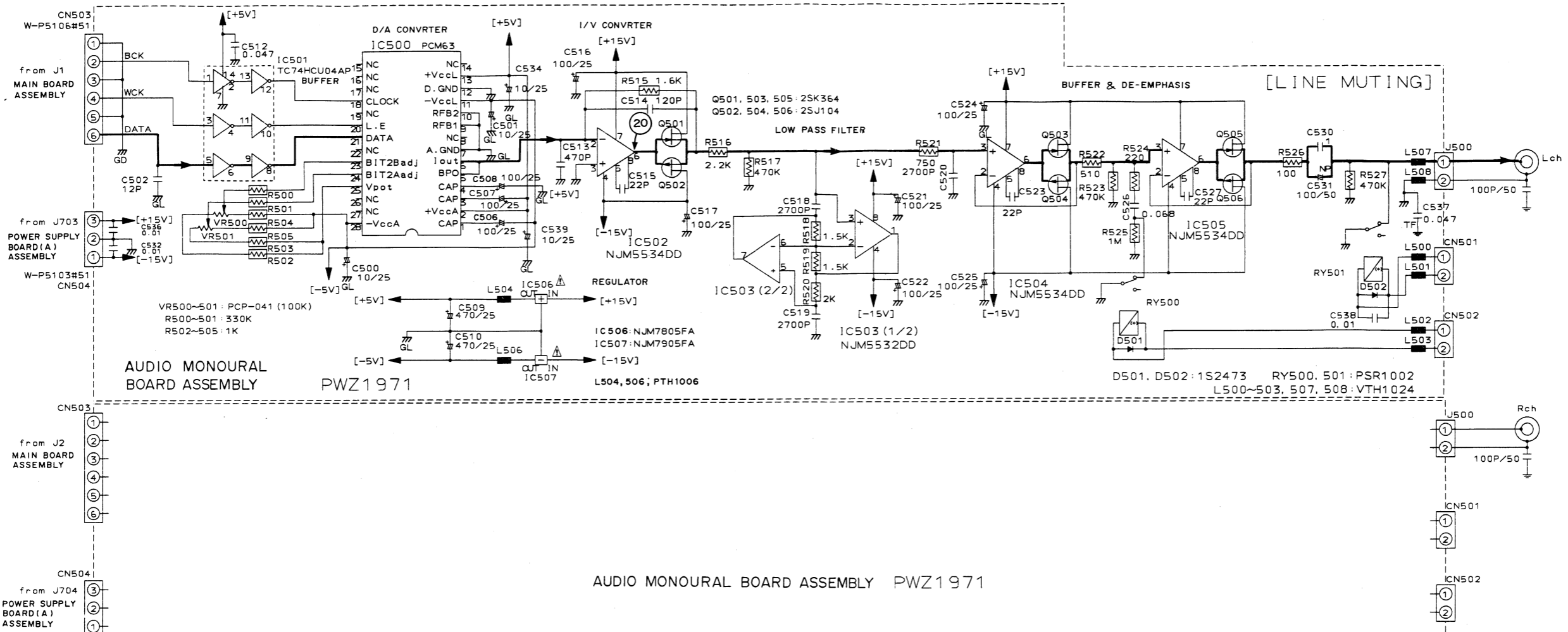

AUDIO MONORAL BOARD ASSEMBLY PWZ1971

CAUTION: FOR CONTINUED PROTECTION AGAINST RISK OF FIRE, REPLACE WITH SAME TYPE NO. ICP-N20 MFD BY ROHM CO., LTD. FOR IC800-IC803.

CAUTION: FOR CONTINUED PROTECTION AGAINST RISK OF FIRE, REPLACE WITH SAME TYPE NO. ICP-N10 MFD BY ROHM CO., LTD. FOR IC701 AND IC702.

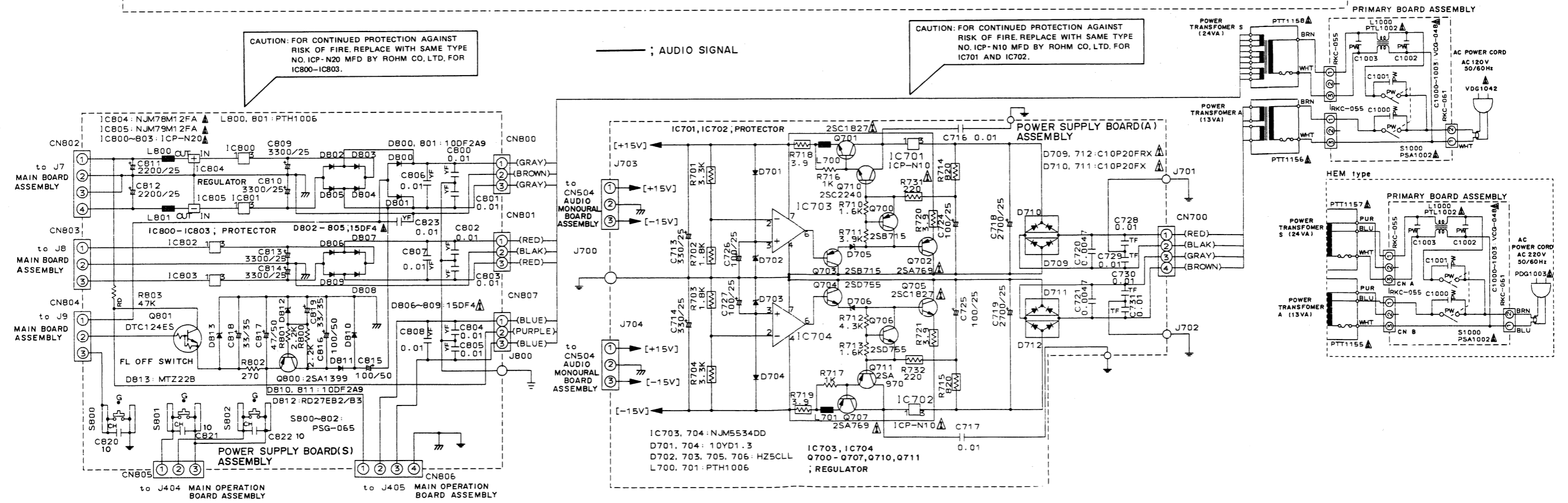

1 2 3 4 5 6

Wave Forms

NOTE: The encircled numbers denote measuring points in the schematic diagram.

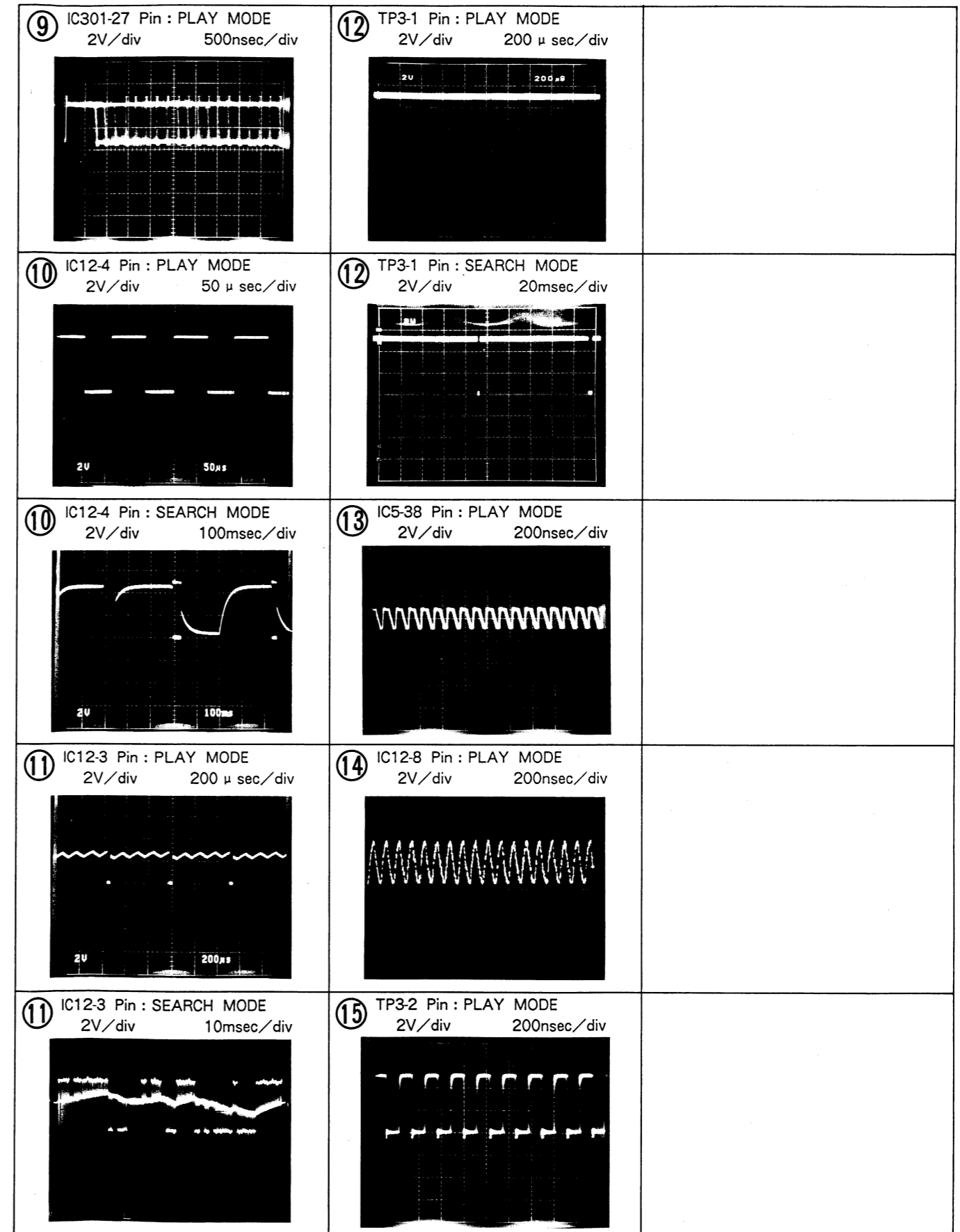
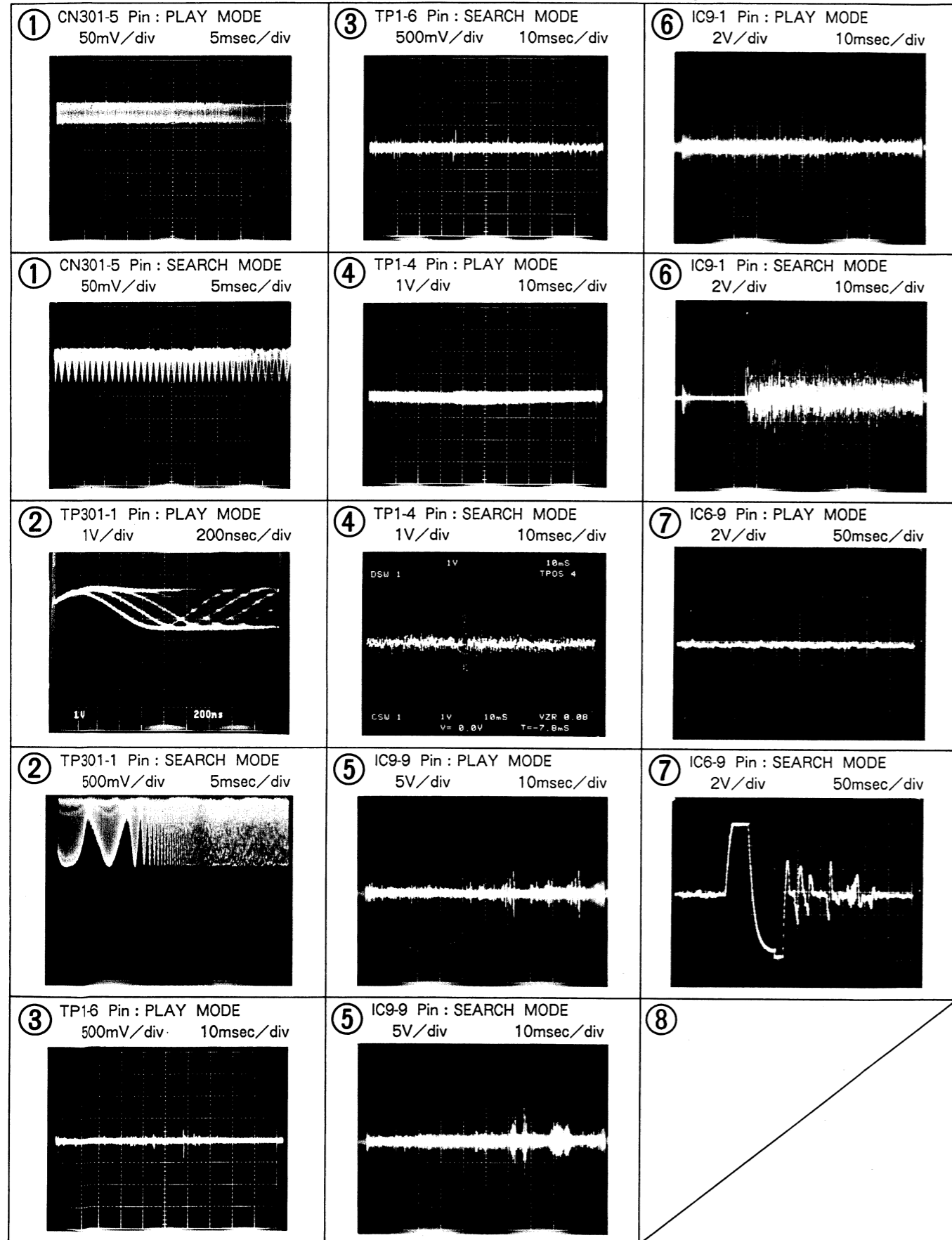

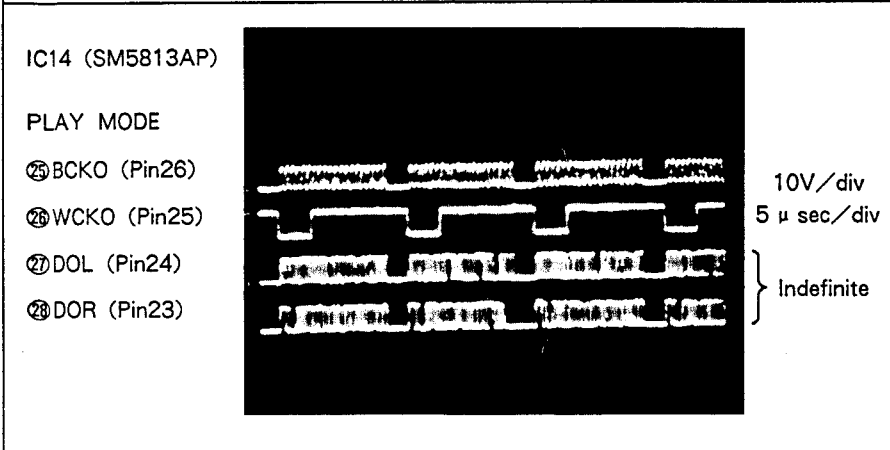
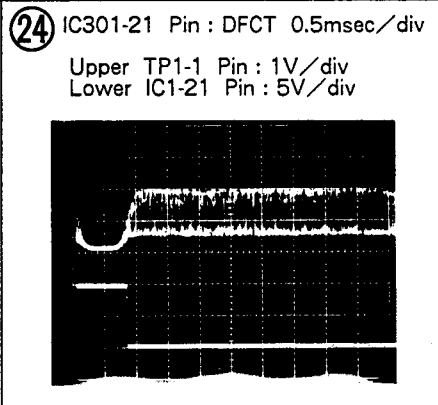
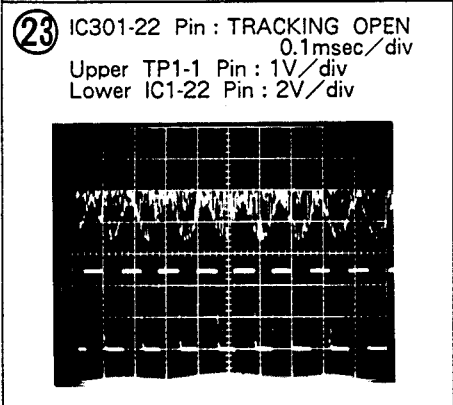
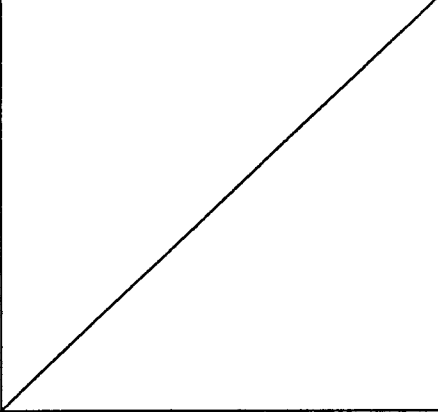
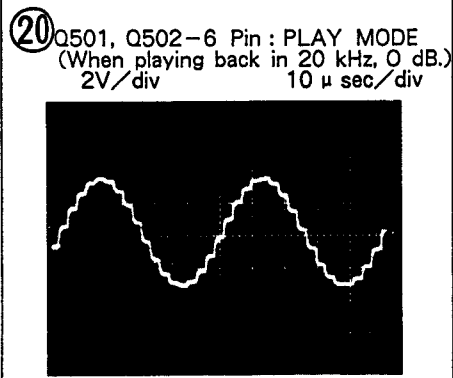
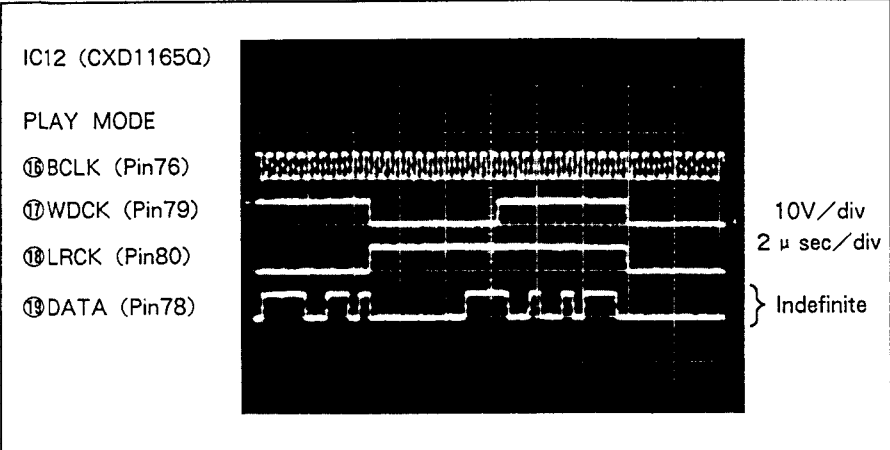

## 7. P.C.B's PARTS LIST

### NOTES:

- Parts without part number cannot be supplied.
- Parts marked by "⊙" are not always kept in stock. Their delivery time may be longer than usual or they may be unavailable.
- The Δ mark found on some component parts indicates the importance of the safety factor of the part. Therefore, when replacing, be sure to use parts of identical designation.
- When ordering resistors, first convert resistance values into code form as shown in the following examples.

Ex.1 When there are 2 effective digits (any digit apart from 0), such as 560 ohm and 47k ohm (tolerance is shown by J=5%, and K=10%)

560 Ω → 56 × 10<sup>1</sup> → 561 ..... RD1/4PS 

5	6	1
---	---	---

 J  
 47k Ω → 47 × 10<sup>3</sup> → 473 ..... RD1/4PS 

4	7	3
---	---	---

 J  
 0.5 Ω → 0R5 ..... RN2H 

0	R	5
---	---	---

 K  
 1 Ω → 010 ..... RS1P 

0	1	0
---	---	---

 K

Ex.2 When there are 3 effective digits (such as in high precision metal film resistors).

5.62k Ω → 562 × 10<sup>1</sup> → 5621 ..... RN1/4SR 

5	6	2	1
---	---	---	---

 F

Mark	No.	Symbol & Description	Part No.
⊙	<b>MAIN OPERATION BOARD ASSEMBLY (PWZ1742)</b>		

#### SEMICONDUCTORS

IC401 MICROCOMPUTER	PDG036
Q401 TRANSISTOR	2SC1740S
Q402-406 TRANSISTOR	DTA124ES
D401	SLH-56MC3H

#### SWITCHES

S401-403 SWITCH	PSG-065
S406, 407 SWITCH	PSG-065

#### COILS/TRANSFORMERS

L401, 402	LRA010K
F401 FILTER	VTH1001

#### CAPACITORS

C401 ELECTR. CAPACITOR	CEJA101M10
C402, 403	CKPUYF103Z25
C404 ELECTR. CAPACITOR	CEJA101M10
C405 CERAMIC CAPACITOR	CGCYF473Z25
C406 CERAMIC CAPACITOR	CKCYF103Z50
C407, 408 CERAMIC CAPACITOR	CGCYF473Z25
C409, 410	CKPUYF103Z25
C411-413	CCPUCH100J50
C416, 417	CCPUCH100J50

#### RESISTORS

R401, 402 CARBONFILM RESISTOR	RD1/6PM□□□J
R404-407 CARBONFILM RESISTOR	RD1/6PM□□□J
R408 RESISTOR ARRAY (47K)	RA10S□□□J
R409-418 CARBONFILM RESISTOR	RD1/6PM□□□J

#### OTHERS

INFRARED RAYS RECEIVER	GPIU52X
V401 FLUORESCENT TUBE	PEL1025

### SUB OPERATION BOARD ASSEMBLY

#### SEMICONDUCTORS

D201	SLH-34YC3H3
D202, 203	SLH-34VC3H3
D204	SLH-34YC3H3

Mark	No.	Symbol & Description	Part No.
------	-----	----------------------	----------

#### SWITCHES

S201-203 SWITCH	PSG-065
-----------------	---------

#### CAPACITORS

C201-203	CKPUYF103Z25
C211-213	CCPUCH100J50

### LED BOARD ASSEMBLY

#### SEMICONDUCTORS

D901	SLH-56VC3H
------	------------

#### CAPACITORS

C901	CKPUYF103Z25
------	--------------

### AUDIO MONAURAL BOARD ASSEMBLY

#### SEMICONDUCTORS

IC500 D/A CONVERTER, IC	PCM63P-K
IC501	TC74HCU04AP
IC502	NJM5534DD
IC503	NJM5532DD
IC504, 505	NJM5534DD
Δ IC506	NJM7805FA
Δ IC507	NJM7905FA
Q501	2SK364
Q502	2SJ104
Q503	2SK364
Q504	2SJ104
Q505	2SK364
Q506	2SJ104
D501, 502 DIODE	1S2473

#### RELAYS

RY500, 501 RELAY	PSR1002
------------------	---------

#### COILS/TRANSFORMERS

L500-503 FERRITE BEAD	VTH1024
L504	PTH1006
L506	PTH1006
L507, 508 FERRITE BEAD	VTH1024

**Mark No. Symbol & Description Part No.**

**CAPACITORS**

C500, 501 (10/25) PCH1063  
 C502 CERAMIC CAPACITOR CCCCH120J50  
 C506-508 ELECTR. CAPACITOR CENA101M25  
 C509, 510 ELECTR. CAPACITOR CENA471M25  
 C512 AUDIO FILM CAPACITOR CFTXA473J50

C513 PCL1008  
 C514 PCL1007  
 C515 MICA CAPACITOR CMA220J500  
 C516, 517 (100/25) PCH1084  
 C518-520 PCL1026

C521, 522 (100/25) PCH1084  
 C523 MICA CAPACITOR CMA220J500  
 C524, 525 (100/25) PCH1084  
 C526 PCL1009  
 C527 MICA CAPACITOR CMA220J500

C530 PCL1025  
 C531 (100/50) PCH1088  
 C532 AUDIO FILM CAPACITOR CFTXA103J50  
 C534 (10/25) PCH1063  
 C536 AUDIO FILM CAPACITOR CFTXA103J50

C537 AUDIO FILM CAPACITOR CFTXA473J50  
 C538 CERAMIC CAPACITOR CKCYF103Z50  
 C539 (10/25) PCH1063

**RESISTORS**

R500-505 RDM1/2P□□□J  
 R515, 516 CARBONFILM RESISTOR RDM1/2P□□□F  
 R517 RDM1/2P□□□J  
 R518-522 CARBONFILM RESISTOR RDM1/2P□□□F  
 R523-527 RDM1/2P□□□J

VR500, 501 PCP-041

**POWER SUPPLY BOARD (A) ASSEMBLY**

**SEMICONDUCTORS**

△ IC701, 702 IC PROTECTOR ICP-N10  
 IC703, 704 NJM5534DD  
 Q700 TRANSISTOR 2SB715  
 △ Q701 TRANSISTOR 2SC1827  
 △ Q702 TRANSISTOR 2SA769

Q703 TRANSISTOR 2SB715  
 Q704 TRANSISTOR 2SD755  
 △ Q705 TRANSISTOR 2SC1827  
 Q706 TRANSISTOR 2SD755  
 △ Q707 TRANSISTOR 2SA769

Q710 TRANSISTOR 2SC2240  
 Q711 TRANSISTOR 2SA970  
 D701 C. R. D. 10YD1. 3  
 D702, 703 HZ5CLL  
 D704 C. R. D. 10YD1. 3

D705, 706 HZ5CLL  
 △ D709 C10P20FRX  
 △ D710, 711 C10P20FX  
 △ D712 C10P20FRX

**Mark No. Symbol & Description Part No.**

**COILS/TRANSFORMERS**

L700, 701 PTH1006

**CAPACITORS**

C713, 714 ELECTR. CAPACITOR CENA331M25  
 C716, 717 CERAMIC CAPACITOR CKCYF103Z50  
 C718, 719 (2700/25) PCH1064  
 C720, 721 PCL1006  
 C724-727 ELECTR. CAPACITOR CENA101M25

C728-731 AUDIO FILM CAPACITOR CFTXA103J50

**RESISTORS**

R701-704 RDM1/2P□□□J  
 R710-713 CARBONFILM RESISTOR RDR1/4PM□□□F  
 R714, 715 RDM1/2P□□□J  
 R716, 717 CARBONFILM RESISTOR RDR1/4PM□□□J  
 R718-721 RDM1/2P□□□J

R731, 732 RDM1/2P□□□J

**POWER SUPPLY BOARD (S) ASSEMBLY**

**SEMICONDUCTORS**

△ IC800-803 IC PROTECTOR ICP-N20  
 △ IC804 NJM78M12FA  
 △ IC805 NJM79M12FA  
 Q800 TRANSISTOR 2SA1399  
 Q801 TRANSISTOR DTC124ES

D800, 801 10DF2FA9  
 △ D802-809 15DF4  
 D810, 811 10DF2FA9  
 D812 ZENER DIODE RD27EB2  
 D813 MTZ22B

**SWITCHES**

S800-802 SWITCH PSG-065

**COILS/TRANSFORMERS**

L800, 801 PTH1006

**CAPACITORS**

C800-808 CERAMIC CAPACITOR CKCYF103Z50  
 C809, 810 (3300/25) PCH1086  
 C811, 812 (2200/25) PCH1087  
 C813, 814 (3300/25) PCH1086  
 C815, 816 ELECTR. CAPACITOR CENA101M50

C817 ELECTR. CAPACITOR CENA470M50  
 C818, 819 ELECTR. CAPACITOR CEAS330M35  
 C820-822 CERAMIC CAPACITOR CCCCH100D50  
 C823 CERAMIC CAPACITOR CKCYF103Z50

**RESISTORS**

R800-802 CARBONFILM RESISTOR RDR1/4PM□□□J  
 R803 CARBONFILM RESISTOR RD1/4PM□□□J

**PRIMARY BOARD ASSEMBLY**

**SWITCHES**

△ S1000 PSA1002

**COILS/TRANSFORMERS**

△ L1000 FILTER PTL1002

Mark No. Symbol & Description Part No.

**CAPACITORS**

△ C1000-1003 CAPACITOR (CERAMIC) VCG-048

**OTHERS**

CAPACITOR COVER REC-297

⊙ MAIN BOARD ASSEMBLY(PWM1285)

**SEMICONDUCTORS**

△ IC1 TA7256P  
 △ IC100 AN7810F  
 △ IC101 AN7910F  
 △ IC102 AN7810F  
 △ IC103 AN7910F  
  
 △ IC104 AN7810F  
 △ IC105 AN7910F  
 IC12 EFM DEMODULATION IC CXD1165Q  
 IC14 IC SM5813AP  
 IC151 TC74HCU04AP  
  
 IC16 TC74HCU04AP  
 IC19 TC74HC74AP  
 IC2 TC74HCU04AP  
 △ IC20, 21 NJM7805FA  
 △ IC22 NJM7905FA  
  
 △ IC26 NJM7805FA  
 IC3 MICROCOMPUTER, IC PD3154  
 IC301 PRE AMP IC CXA1081S  
 IC5 SERVO CONTROL IC CXA1082AS  
 △ IC6 TA7256P  
  
 IC7, 8 NJM072DE  
 △ IC9 TA7256P  
 Q1 TRANSISTOR 2SC1740SLN  
 Q11 TRANSISTOR 2SC1740SLN  
 Q12 TRANSISTOR DTA124ES  
  
 Q10, Q15 TRANSISTOR 2SC1740S  
 Q151, 152 TRANSISTOR DTC124ES  
 Q16 TRANSISTOR 2SA933S  
 Q17 TRANSISTOR 2SC3581  
 Q18 TRANSISTOR DTA124ES  
  
 Q19 TRANSISTOR 2SC3581  
 Q20-22 TRANSISTOR DTC124ES  
 Q301-303 TRANSISTOR 2SC1740SLN  
 Q304 TRANSISTOR 2SA1399  
 Q8 TRANSISTOR DTC124ES  
  
 Q9 TRANSISTOR 2SA933S  
 D1201-1204 DIODE 1SS254  
 D151, 152 DIODE 1SS254  
 D24 DIODE 1SS254  
 D40-43 DIODE 1SS254  
  
 D7-9 DIODE 1SS254

**COILS/TRANSFORMERS**

L1 LRA010K  
 L10-12 PTH1006  
 L1201 COIL PTL1001  
 L13-16 PTH1006  
 L17, 18 VTH1017

Mark No. Symbol & Description Part No.

L2, 3 LRA010K  
 L5 LRA010K  
 L6, 7 FERRITE BEAD VTH1024  
 L8 VTH1013  
 L9 PTH1006

F1 FILTER VTH1001  
 F301 FILTER VTH1001

**CAPACITORS**

C1 ELECTR. CAPACITOR CEAS101M10  
 C10 CERAMIC CAPACITOR CCCCH300J50  
 C101 ELECTR. CAPACITOR CEAS100M50  
 C102 MYLOR FILM CAPACITOR CQMA472J50  
 C103 CERAMIC CAPACITOR CKCYF103Z50  
  
 C104, 105 ELECTR. CAPACITOR CENA101M25  
 C106, 107 MYLOR FILM CAPACITOR CQMA104J50  
 C108 CERAMIC CAPACITOR CKCYF103Z50  
 C109, 110 ELECTR. CAPACITOR CENA101M25  
 C111 CERAMIC CAPACITOR CKCYF103Z50  
  
 C112 (3. 3/25) PCH1083  
 C113, 114 ELECTR. CAPACITOR CENA101M25  
 C115, 116 CERAMIC CAPACITOR CKCYF103Z50  
 C117 CERAMIC CAPACITOR CCCSL471J50  
 C12 MYLOR FILM CAPACITOR CQMA471J50  
  
 C1201 CERAMIC CAPACITOR CGCYF473Z25  
 C1202 ELECTR. CAPACITOR CENA101M25  
 C121, 122 CERAMIC CAPACITOR CGCYF473Z25  
 C126-128 CERAMIC CAPACITOR CKCYF103Z50  
 C129 CERAMIC CAPACITOR CGCYF473Z25  
  
 C13 CERAMIC CAPACITOR CKCYF103Z50  
 C131-135 CERAMIC CAPACITOR CKCYF103Z50  
 C14 ELECTR. CAPACITOR CEAS101M10  
 C140 CERAMIC CAPACITOR CKCYF103Z50  
 C145 CERAMIC CAPACITOR CCCSL101J50  
  
 C15 CERAMIC CAPACITOR CGCYF473Z25  
 C151 CERAMIC CAPACITOR CKCYF103Z50  
 C152 ELECTR. CAPACITOR CENA101M25  
 C16 MYLOR FILM CAPACITOR CQMA104J50  
 C17 ELECTR. CAPACITOR CEANP470M10  
  
 C18, 19 MYLOR FILM CAPACITOR CQMA104J50  
 C2 CERAMIC CAPACITOR CGCYF473Z25  
 C20 MYLOR FILM CAPACITOR CQMA102J50  
 C21 CERAMIC CAPACITOR CGCYF473Z25  
 C22 CERAMIC CAPACITOR CCCSL680J50  
  
 C24 MYLOR FILM CAPACITOR CQMA152J50  
 C25 MYLOR FILM CAPACITOR CQMA153J50  
 C27 ELECTR. CAPACITOR CENA221M10  
 C28, 29 CERAMIC CAPACITOR CGCYF473Z25  
 C30 ELECTR. CAPACITOR CENA221M10  
  
 C301 MYLOR FILM CAPACITOR CQMA472J50  
 C302 CERAMIC CAPACITOR CCCCH300J50  
 C303 ELECTR. CAPACITOR CEAS101M10  
 C304 MYLOR FILM CAPACITOR CQMA333J50  
 C305 MYLOR FILM CAPACITOR CQMA332J50  
  
 C306 MYLOR FILM CAPACITOR CQMA103J50

Mark	No.	Symbol & Description	Part No.
	C307	ELECTR. CAPACITOR	CEAS101M10
	C308, 309	ELECTR. CAPACITOR	CENA221M10
	C31	MYLOR FILM CAPACITOR	CQMA333J50
	C310, 311	CERAMIC CAPACITOR	CKDYF103Z50
	C312, 313	ELECTR. CAPACITOR	CENA221M25
	C314		CCCSL561J50
	C315	CERAMIC CAPACITOR	CKDYF103Z50
	C316	ELECTR. CAPACITOR	CEASR47M50
	C317	MYLOR FILM CAPACITOR	CQMA103J50
	C318	ELECTR. CAPACITOR	CEAS101M10
	C32	ELECTR. CAPACITOR	CEASR47M50
	C320, 321	CERAMIC CAPACITOR	CGCYF473Z25
	C322, 323	CERAMIC CAPACITOR	CCCH300J50
	C324-327	CERAMIC CAPACITOR	CCCH120J50
	C33	CERAMIC CAPACITOR	CGCYF473Z25
	C34	ELECTR. CAPACITOR	CEAS220M50
	C35	ELECTR. CAPACITOR	CENA221M10
	C36	CERAMIC CAPACITOR	CGCYF473Z25
	C37, 38	ELECTR. CAPACITOR	CENA101M25
	C39	ELECTR. CAPACITOR	CEAS101M10
	C4	CERAMIC CAPACITOR	CGCYF473Z25
	C40 (47000/5.5)		PCH1062
	C41	MYLOR FILM CAPACITOR	CQMA332J50
	C42	CERAMIC CAPACITOR	CCCSL101J50
	C43	ELECTR. CAPACITOR	CEAS330M35
	C44	MYLOR FILM CAPACITOR	CQMA332J50
	C45	ELECTR. CAPACITOR	CEAS330M35
	C46	CERAMIC CAPACITOR	CCCSL150J50
	C47, 48	CERAMIC CAPACITOR	CCCH080D50
	C49	ELECTR. CAPACITOR	CENA101M25
	C5	MYLOR FILM CAPACITOR	CQMA224J50
	C50, 51	CERAMIC CAPACITOR	CKCYF103Z50
	C52	ELECTR. CAPACITOR	CEAS332M16
	C53 (3.3/25)		PCH1083
	C54	CERAMIC CAPACITOR	CKCYF103Z50
	C55	ELECTR. CAPACITOR	CENA101M25
	C56	CERAMIC CAPACITOR	CKCYF103Z50
	C57	AUDIO FILM CAPACITOR	CFTXA103J50
	C58	ELECTR. CAPACITOR	CEYA330M25
	C6	MYLOR FILM CAPACITOR	CQMA473J50
	C60	ELECTR. CAPACITOR	CENA101M25
	C61, 62	CERAMIC CAPACITOR	CKCYF103Z50
	C63	ELECTR. CAPACITOR	CENA101M25
	C65	ELECTR. CAPACITOR	CEAS101M10
	C66	ELECTR. CAPACITOR	CEANP100M25
	C67, 68	CERAMIC CAPACITOR	CKDYF103Z50
	C7	MYLOR FILM CAPACITOR	CQMA124J50
	C74-76	AUDIO FILM CAPACITOR	CFTXA103J50
	C77, 78 (3.3/25)		PCH1083
	C79, AUDIO	FILM CAPACITOR	CFTXA103J50
	C8	MYLOR FILM CAPACITOR	CQMA223J50
	C80, 81	AUDIO FILM CAPACITOR	CFTXA103J50
	C82-84	ELECTR. CAPACITOR	CENA222M16
	C85, 86	CERAMIC CAPACITOR	CCCSL101J50

Mark	No.	Symbol & Description	Part No.
	C88	ELECTR. CAPACITOR	CENA101M25
	C89	MYLOR FILM CAPACITOR	CQMA102J50
	C9	CERAMIC CAPACITOR	CGCYF473Z25
	C90	ELECTR. CAPACITOR	CENA101M25
	C91	MYLOR FILM CAPACITOR	CQMA103J50
	C92	MYLOR FILM CAPACITOR	CQMA102J50
	C93	ELECTR. CAPACITOR	CEAS330M35
	C94	CERAMIC CAPACITOR	CKCYF103Z50
	C95	ELECTR. CAPACITOR	CEAS330M35
	C96-99	CERAMIC CAPACITOR	CKCYF103Z50
<b>RESISTORS</b>			
	R1	CARBONFILM RESISTOR	RD1/6PM□□□J
	R10	CARBONFILM RESISTOR	RD1/6PM□□□J
	R100-108	CARBONFILM RESISTOR	RD1/6PM□□□J
	R109	CARBONFILM RESISTOR	RDR1/2PM□□□J
	R11	CARBONFILM RESISTOR	RD1/6PM□□□J
	R110, 111	CARBONFILM RESISTOR	RD1/6PM□□□J
	R115, 116	CARBONFILM RESISTOR	RD1/6PM□□□J
	R12	CARBONFILM RESISTOR	RD1/6PM□□□J
	R1201	CARBONFILM RESISTOR	RDR1/4PM□□□J
	R1202	CARBONFILM RESISTOR	RD1/6PM□□□J
	R122-125	CARBONFILM RESISTOR	RD1/6PM□□□J
	R127-133	CARBONFILM RESISTOR	RD1/6PM□□□J
	R14	CARBONFILM RESISTOR	RDR1/2PM□□□J
	R15	CARBONFILM RESISTOR	RD1/6PM□□□J
	R151-156	CARBONFILM RESISTOR	RD1/6PM□□□J
	R16-18	CARBONFILM RESISTOR	RD1/6PM□□□J
	R19	CARBONFILM RESISTOR	RDR1/2PM□□□J
	R2	CARBONFILM RESISTOR	RD1/6PM□□□J
	R20	CARBONFILM RESISTOR	RDR1/2PM□□□J
	R21-30	CARBONFILM RESISTOR	RD1/6PM□□□J
	R301-303	CARBONFILM RESISTOR	RD1/6PM□□□J
	R304	CARBONFILM RESISTOR	RDR1/2PM□□□J
	R305-307	CARBONFILM RESISTOR	RD1/6PM□□□J
	R31	METAL FILM RESISTOR	RN1/6PQ□□□□J
	R310-312	CARBONFILM RESISTOR	RD1/6PM□□□J
	R314-319	CARBONFILM RESISTOR	RD1/6PM□□□J
	R32	CARBONFILM RESISTOR	RD1/6PM□□□J
	R320	CARBONFILM RESISTOR	RD1/6PM□□□J
	R323-326	CARBONFILM RESISTOR	RDR1/2PM□□□J
	R327, 328	CARBONFILM RESISTOR	RD1/6PM□□□J
	R329	CARBONFILM RESISTOR	RDR1/2PM□□□J
	R33	CARBONFILM RESISTOR	RD1/6PM□□□J
	R330	CARBONFILM RESISTOR	RDR1/2PM□□□J
	R331-335	CARBONFILM RESISTOR	RD1/6PM□□□J
	R34-39	CARBONFILM RESISTOR	RD1/6PM□□□J
	R4	CARBONFILM RESISTOR	RD1/6PM□□□J
	R40-49	CARBONFILM RESISTOR	RD1/6PM□□□J
	R5	CARBONFILM RESISTOR	RD1/6PM□□□J
	R50-55	CARBONFILM RESISTOR	RD1/6PM□□□J
	R57, 58	CARBONFILM RESISTOR	RD1/6PM□□□J
	R6	CARBONFILM RESISTOR	RD1/6PM□□□J
	R60	CARBONFILM RESISTOR	RD1/6PM□□□J
	R62-69	CARBONFILM RESISTOR	RD1/6PM□□□J
	R7	CARBONFILM RESISTOR	RD1/2PM2R2J

Mark	No.	Symbol & Description	Part No.
	R70	CARBONFILM RESISTOR	RD1/6PM□□□J
	R73-79	CARBONFILM RESISTOR	RD1/6PM□□□J
	R8	CARBONFILM RESISTOR	RD1/6PM□□□J
	R80-85	CARBONFILM RESISTOR	RD1/6PM□□□J
	R89	CARBONFILM RESISTOR	RD1/6PM□□□J
	R9	CARBONFILM RESISTOR	RD1/6PM□□□J
	R90	CARBONFILM RESISTOR	RD1/6PM□□□J
	R91	CARBONFILM RESISTOR	RD1/2PM2R2J
	R92-99	CARBONFILM RESISTOR	RD1/6PM□□□J
	VR1	VR	VRTB6VS473
	VR2	SEMI-FIXED RESISTOR	VRTB6VS103
	VR3-7	VR	VRTB6VS223
	VR8	VR	VRTS6VS102
	VR9	VR	VRTB6VS473
<b>OTHERS</b>			
	CN301		5597-17CPB
	CN302		5597-05CPB
	DL301, 302	FILTER	PTF1009
	JA1201		TOTX174
	JA1202	JACK	PKB1004
	X1	XTAL RES (OSC)	PSS1001



## 8. ADJUSTMENTS

Perform the following adjustments in the indicated order.

### ● Adjustments

1. Tracking error offset, focus error offset and RF offset adjustment.
2. Tracking return offset and focus return offset adjustment.
3. Focus lock and spindle lock check.
4. Grating adjustment.
5. Tracking balance adjustment.
6. Tangential adjustment
7. Radial adjustment
8. RF level check
9. LD (laser diode) power check
10. Focus gain adjustment
11. Tracking gain adjustment
12. VCO free-running frequency adjustment
13. Method of focus error check
14. D/A converter adjustment

### ● Measuring Devices

1. Dual-trace oscilloscope
2. Light power meter
3. YEDS-7 test disc
4. Focus and tracking adjustment filter
5. Loop gain adjustment band-pass filter
6. Signal generator
7. Grating driver
8. General-use tools
9. Commercial available disc (8 cm and 12 cm)

**Note)** The volumes of VR500 to VR503 and VR501 of D/A converter section are adjusted when shipping, therefore, do not touch or adjust them.

( Adjust them when D/A converter IC (PCM63MP-K) is exchanged. )

### ● Test Mode

#### Setting and Canceling the Test Mode

- ① Turn the POWER switch (S1000) while pressing the test mode switch (S800).
- ② To cancel the test mode, turn the POWER switch OFF.

In the test mode, each key works as shown in Table 1.

### ● Adjustment Volume Name

- VR1: Focus return offset (FR. OF)
- VR2: RF offset (RF. OF)
- VR3: Focus gain (FO. GA)
- VR4: Tracking gain (TR. GA)
- VR5: Tracking balance (TR. BL)
- VR6: Focus error offset (FO. OF)
- VR7: Tracking error offset (TE. OF)
- VR8: VCO frequency counter (VCOA)
- VR9: Tracking return offset (TR. OF)

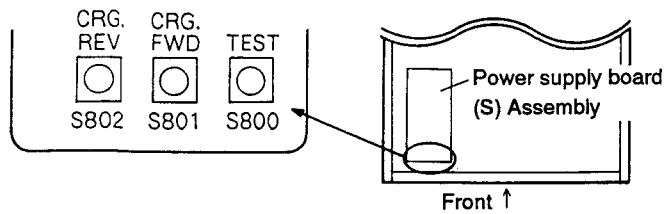

Note) In PD-93, MANUAL SEARCH is not set on the front panel. Therefore, use the switches of the power supply board (S) assembly when moving the carriage in the test mode.

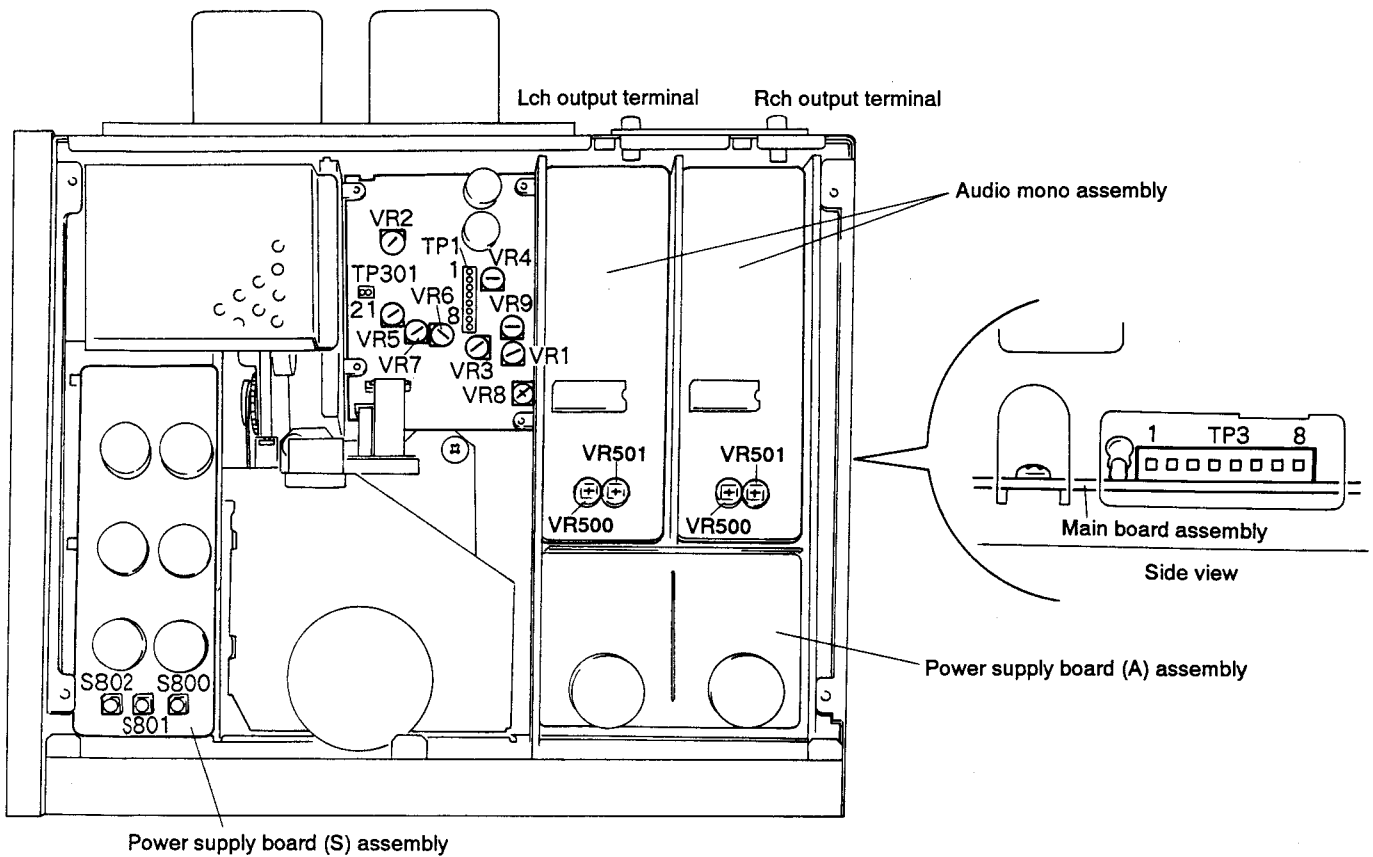
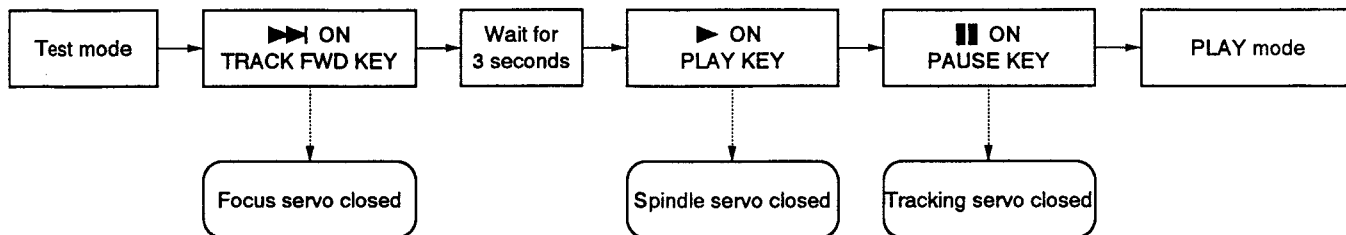

Fig. 1. Adjusting Points

In the test mode, closing and opening of servos is performed independently. Therefore, to set the play mode the servos have to be closed in (serial) sequence. Remember that in the test mode the play mode can't be set simply by pressing PAUSE (||) key.

For example, to set the play mode from the stop mode, press the following keys in the indicated order.



\* In the test mode, servos keep a serial sequence.

● Function of Each Key in the Test Mode

Symbol	Key name	Function during test mode	Description
◀◀	TRACK BACK	Laser diode ON	Lights the laser diode.
▶▶	TRACK FWD	Focus servo close	Lights the laser diode and sets the focus actuator UP/DOWN to close the focus servo.
▶	PLAY	Spindle servo close	After kicking the spindle motor, it closes the servo in the CLV-H mode.
	PAUSE	Tracking servo close/open	Performs a toggle operation. When pressed, the tracking servo is closed and the unit enters the play mode (the focus servo and spindle servo should be already closed). At this time the PAUSE indicator lights. If pressed again, the tracking servo opens.
S802	CRG. REV	Carriage reverse (inward)	Moves the carriage inwards at high (approx. 1 cm/s) speed. Since there is no safety device to stop the carriage, be sure to stop it manually in time.
S801	CRG. FWD	Carriage forward (outward)	Moves the carriage outwards at high (approx. 1 cm/s) speed. Since there is no safety device to stop the carriage, be sure to stop it manually in time.
■	STOP	Stop	Stops all servos and returns the unit to the initial condition.
▲	OPEN/CLOSE	(Disc tray) open/close	Opens and closes the disc tray. However, the pickup does not return to the rest position when the tray is opened. It does not move either when the tray is closed.

Table 1.

Step No.	Oscilloscope setting		Test points	Adjusting points	Check items/ adjustment specifications	Adjustment procedure
	V	H				
<b>1</b>	<b>Tracking error offset, focus error offset and RF offset adjustment</b>					
		TP1	TP1 Pin 4 (TR. ER)	VR7 (TE. OF)	0V ± 50 mV	<ul style="list-style-type: none"> <li>● Set the test mode. (*)</li> <li>● Adjust VR7 (TE. OF: tracking error offset) so that the voltage at Pin 4 (TE: tracking error) of TP1 becomes 0V ± 50 mV.</li> <li>● Adjust VR6 (FO. OF: focus error offset) so that the voltage at Pin 6 (FO. ER: focus error) of TP1 becomes 0V ± 50 mV.</li> <li>● Adjust VR2 (RF. OF: RF offset) so that RF output voltage at Pin 1 of TP301 becomes 100 mV ± 50 mV.</li> </ul>
		TP1	TP1 Pin 6 (FO. ER)	VR6 (FO.OF)	0V ± 50 mV	
		TP301	TP301 Pin 1 (RF)	VR2 (RF. OF)	100 mV ± 50 mV	
<b>2</b>	<b>Tracking return offset and focus return offset adjustment</b>					
		TP1	TP1 Pin 2 (TR. RT)	VR9 (TR. OF)	0V ± 10 mV	<ul style="list-style-type: none"> <li>● Set the test mode. (*)</li> <li>● Adjust VR9 (TR. OF: tracking return offset) so that the voltage at Pin 2 TR. RT (tracking return) of TP1 becomes 0V ± 10 mV.</li> <li>● Adjust VR1 (FR. OF: focus return offset) so that the voltage at Pin 8 FO. RT (focus return) of TP1 becomes 35 mV ± 17.5 mV.</li> </ul>
		TP1	TP1 Pin 8 (FO. RT)	VR1 (FR. OF)	35 mV ± 17.5 mV	
<b>3</b>	<b>Focus lock and spindle lock check</b>					
	V 0.5V/div	H 100 msec /div	TP301 Pin 1 (RF output)		RF output  Clockwise rotation	<ul style="list-style-type: none"> <li>● Load the disc.</li> <li>● Set the test mode. (*)</li> <li>● Move the pickup close to the center of the disc using CRG. FWD key (S801). Be sure to perform this operation.</li> <li>● Observe Pin 1 RF (RF output) of TP301 with an oscilloscope and confirm that RF signal is output after pressing TRACK FWD key (▶▶).</li> <li>● Press PLAY key (▶) and confirm that the disc rotates clockwise at approx. normal speed (about 300 rpm around the center of the disc), without running wildly or in reverse direction.</li> </ul>

\* See page 49.

Step No.	Oscilloscope setting		Test points	Adjusting points	Check items/ adjustment specifications	Adjustment procedure
	V	H				
<b>4-1 Grating adjustment (1) (with an 8 cm disc)</b>						
	1V/div	5 ms/div	TP1 Pin 4 (TR. ER)	Grating	Null point	<ul style="list-style-type: none"> <li>● This adjustment can be performed with an 8 cm disc having pits over a 75 mm in diameter.</li> <li>● Load the disc. (8 cm)</li> <li>● Set the test mode. (*)</li> <li>● Press TRACK FWD (▶▶) and PLAY (▶) keys in that order to close the focus and spindle servos (the tracking servo is open state.)</li> <li>● Press CRG. FWD key (S801) and move the pickup to the outer track of the 8 cm disc. When moving the pickup, it is possible to insert a slotted screwdriver in the grating adjustment plate slot from above the unit. (Fig. 3.)</li> <li>● Observe the waveform at Pin 4 TR. ER (tracking error) of TP1 with an oscilloscope and at this time, insert cut off 4 kHz low-pass filter (Fig. 2).</li> <li>● Insert the tracking driver in the adjustment slot and turn it so as to find out the null point (Photo-1).</li> </ul>
	5 mV/div	XY	X axis: R328 Y axis: R327	Grating Grating	Maximum amplitude Phase difference 180°	<ul style="list-style-type: none"> <li>● Turn the grating driver slowly clockwise from the null point and set to the first point where the waveform amplitude (tracking error signal) is maximum. (See photo-2.)</li> <li>● Connect CN301 (PDF) of R328 to X axis of an oscilloscope and CN301 (PDE) of R327 to Y axis on inserting the filters of about 4 kHz of cutoff respectively. Move the pickup to the most outer track of 8 cm disc. At this time, check that the resurge waveform almost is one line, if not adjust. (Photos-4, 5)</li> </ul>

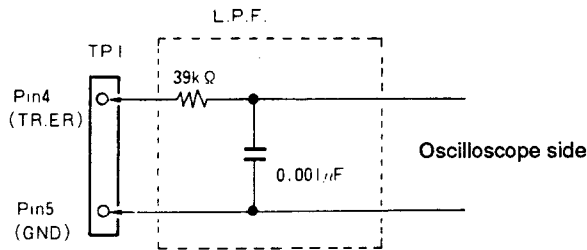
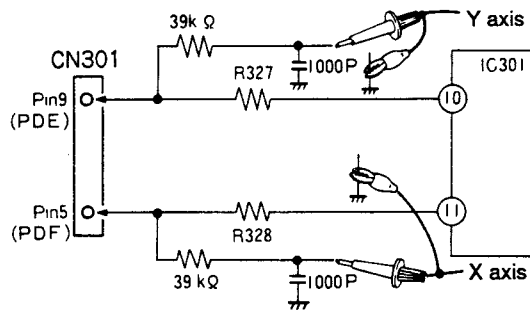

Fig. 2.



\* See page 49.

Step No.	Oscilloscope setting		Test points	Adjusting points	Check items/ adjustment specifications	Adjustment procedure
	V	H				
<b>4-2 Grating adjustment (2) (with an 12 cm disc playing more than 60 minutes)</b>						
	1V/div	5 ms/div	TP1 Pin 4 (TR.ER)	Grating	Null point	<ul style="list-style-type: none"> <li>● Load the disc (playing more than 60 minutes).</li> <li>● Set the test mode. (*)</li> <li>● Press TRACK FWD (▶▶) and PLAY (▶) keys in that order to close the focus and spindle servos (the tracking servo is open state).</li> <li>● Press CRG. FWD key (S801) and move the pickup to the outer track of the disc. When moving the pickup, it is possible to insert a slotted screwdriver in the grating adjustment plate slot from above the unit. (Fig. 3.)</li> <li>● Observe the waveform at Pin 4 TR. ER (tracking error) of TP1 with an oscilloscope and at this time, insert cut off 4 kHz low-pass filter. (Fig. 2.)</li> <li>● Insert the tracking driver in the adjustment slot and turn it so as to find out the null point (Photo-1).</li> </ul>
				Grating	Maximum amplitude	<ul style="list-style-type: none"> <li>● Turn the grating driver slowly clockwise from the null point and set to at the first point where the waveform amplitude (tracking error signal) is maximum. (See photo-2)</li> </ul>
	5 mV/div	5 ms/div	X axis: R328 Y axis: R327	Grating	Phase difference 180°	<ul style="list-style-type: none"> <li>● Connect CN301 (PDF) of R328 to X axis of an oscilloscope and CN301 (PDE) of R327 to Y axis to input with AC coupling, and then move the pickup close to the center track of the disc. At this time, adjust so that the surge waveform almost becomes one line, if not, adjust in the outer track again. (Photos-4, 5)</li> </ul>

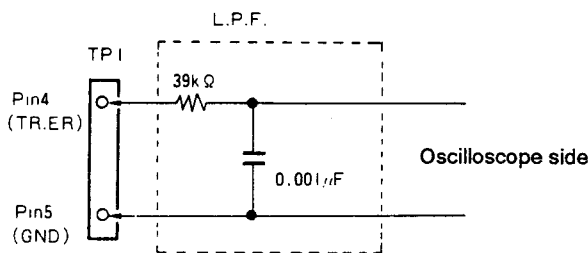

Fig. 2.

\* See page 49.

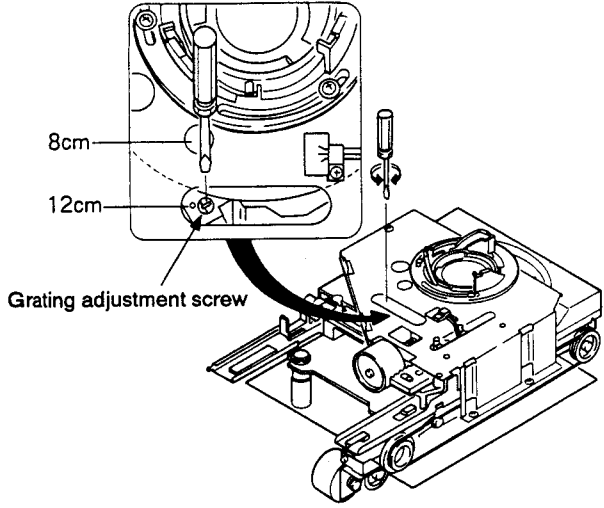

Fig. 3. Grating Adjustment

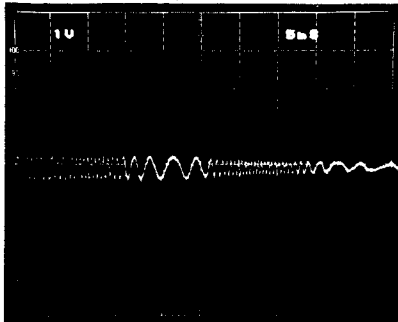

Photo-1 Null point

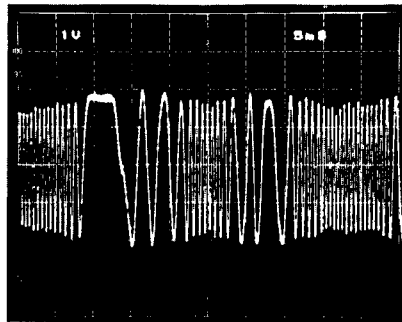

Photo-2 Maximum amplitude

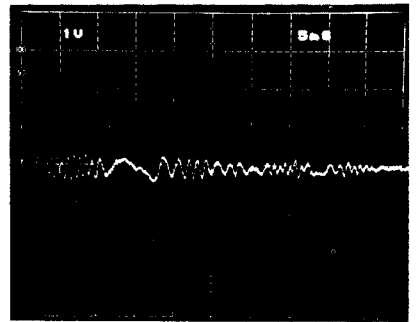

Photo-3 Out of null point

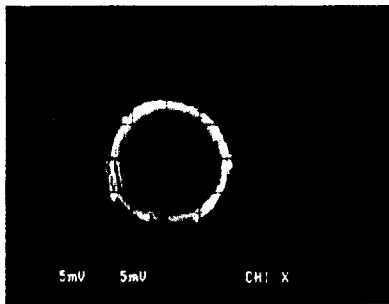

Photo-4

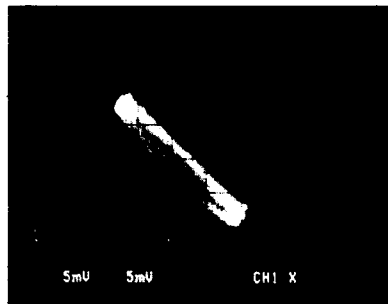
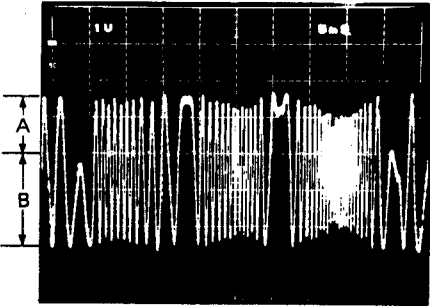
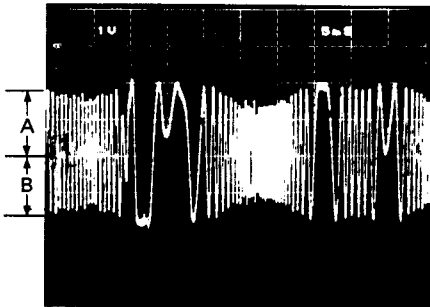

Photo-5

Step No.	Oscilloscope setting		Test points	Adjusting points	Check items/ adjustment specifications	Adjustment procedure
	V	H				
5	<b>Tracking balance adjustment</b>					
	0.5V/div	5 msec/div	TP1 Pin 4 (TR. ER)	VR5 (TR. BL)		<ul style="list-style-type: none"> <li>● Load the disc.</li> <li>● Set the test mode. (*)</li> <li>● Press CRG. FWD key (S801) and move carriage close to the center track of the disc.</li> <li>● Press TRACK FWD (▶▶) and PLAY (▶) keys in that order to turn the disc.</li> <li>● Observe Pin 4 TR. ER (tracking error) of TP1 with an oscilloscope. And adjust VR5 TR. BL (tracking balance) so as to remove DC elements from the tracking error waveform.</li> </ul>
						
			<p style="text-align: center;">Photo-6</p>		<p style="text-align: center;">Photo-7</p>	

\* See page 49.



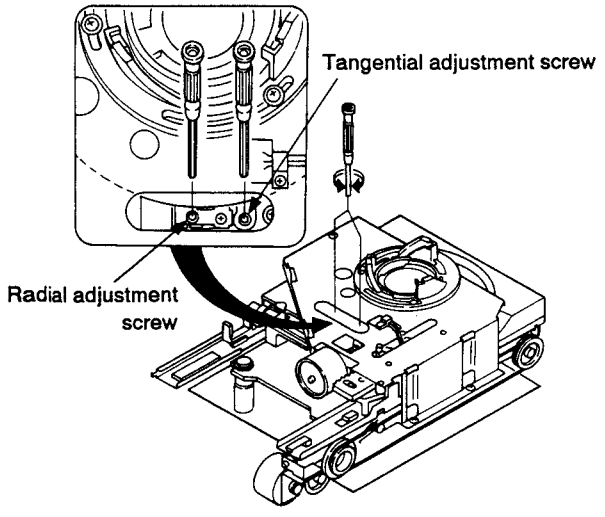

Fig. 4. Tangential Adjustment

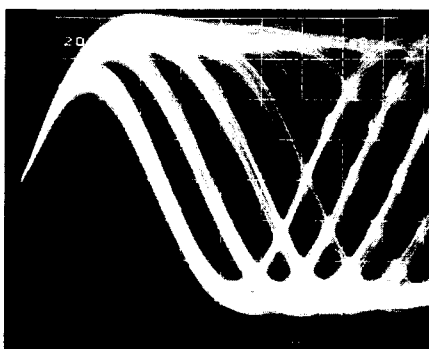

Photo-8

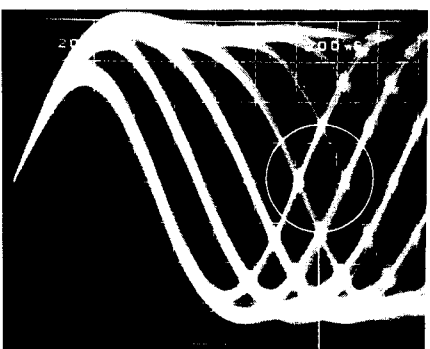

Photo-9

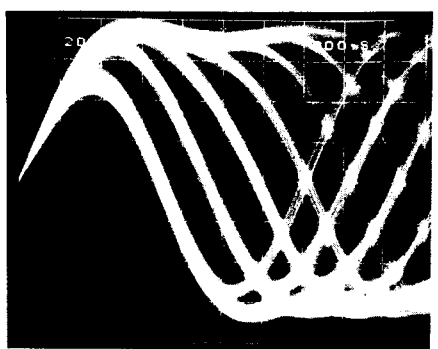
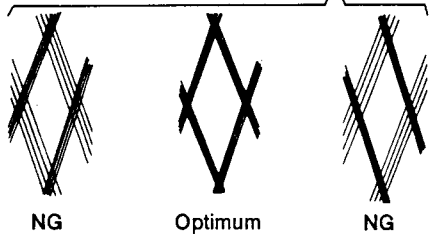
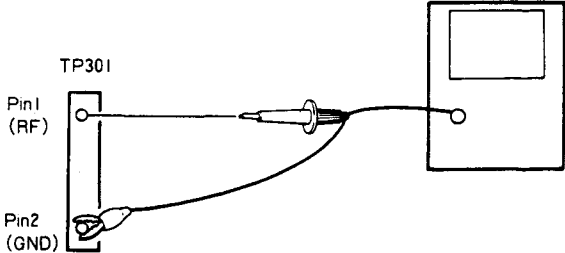

Photo-10

Part to be observed



Step No.	Oscilloscope setting		Test points	Adjusting points	Check items/ adjustment specifications	Adjustment procedure
	V	H				
6	Tangential adjustment					
			TP301 Pin 1 (RF output)	Tangential adjustment screw	Eye pattern optimum point	<ul style="list-style-type: none"> <li>● Load the disc.</li> <li>● Set the test mode. (*)</li> <li>● Press CRG. FWD key (S801) and move the pickup to the center track of the disc (set it to such a location that the tangential screw can be seen from above the servo mechanism. (See fig. 4.)</li> <li>● Press TRACK FWD (▶▶), PLAY (▶) and PAUSE (■) keys in that order to close all servos. (Pause indicator lights.)</li> <li>● Observe Pin 1 RF (RF output) of TP301 with an oscilloscope and adjust the tangential screw so that the eye pattern becomes clear. (Fig. 4.)</li> <li>● The adjustment point is located around the middle location between the point where the eye pattern becomes blurred when turning the tangential screw clockwise and the point where the eye pattern becomes blurred when turning the adjustment screw counterclockwise.</li> </ul> <p>Observe the overall clearness of the waveform and one of the diamond shapes in the eye pattern (photo-9). Optimum adjustment is attained at the point where diamond shape lines are relatively thin.</p>
						 <p style="text-align: center;">Fig. 5</p>

\* See page 49.

Step No.	Oscilloscope setting		Test points	Adjusting points	Check items/ adjustment specifications	Adjustment procedure
	V	H				
7	Radial adjustment					
			TP301 Pin 1 (RF output)	Radial adjustment screw	Eye pattern optimum point	<ul style="list-style-type: none"> <li>● Load the disc.</li> <li>● Set the test mode. (*)</li> <li>● Press CRG. FWD key (S801) and move the pickup to the center track of the disc (set it to such a location that the tangential screw can be seen from above the servo mechanism. (See fig. 4.)</li> <li>● Press TRACK FWD (▶▶), PLAY (▶) and PAUSE (  ) keys in that order to close all servos. (Pause indicator lights.)</li> <li>● Observe Pin 1 RF (RF output) of TP301 with an oscilloscope and adjust the tangential screw so that the eye pattern becomes clear. (Fig. 4.)</li> <li>● The adjustment point is located around the middle location between the point where the eye pattern becomes blurred when turning the tangential screw clockwise and the point where the eye pattern becomes blurred when turning the adjustment screw counterclockwise.</li> </ul> <p>Observe the overall clearness of the waveform and one of the diamond shapes in the eye pattern (photo-9). Optimum adjustment is attained at the point where diamond shape lines are relatively thin.</p> <ul style="list-style-type: none"> <li>● Perform the tangential and radial adjustments alternately two or more times.</li> </ul>

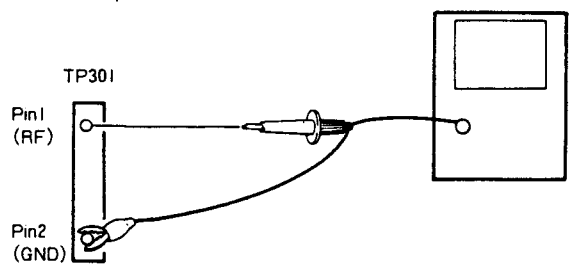

Fig. 5

\* See page 49.

Step No.	Oscilloscope setting		Test points	Adjusting points	Check items/ adjustment specifications	Adjustment procedure
	V	H				
8	RF level check					
			TP301 Pin 1 (RF)	Check	1.5V $\begin{smallmatrix} +0.2V \\ -0V \end{smallmatrix}$	<ul style="list-style-type: none"> <li>● Set the test mode. (*)</li> <li>● Connect the probe of the oscilloscope to Pin 1 RF (RF output) of TP301.</li> <li>● Play back the disc, measure the RF waveform p-p voltage and confirm that it becomes 1.5V <math>\begin{smallmatrix} +0.2V \\ -0V \end{smallmatrix}</math>.</li> <li>● Adjust VR Ⓐ if the voltage does not become 1.5V <math>\begin{smallmatrix} +0.2V \\ -0V \end{smallmatrix}</math>.</li> </ul>
			TP301 Pin 1 (RF)	VR Ⓐ	1.5V $\begin{smallmatrix} +0.2V \\ -0V \end{smallmatrix}$	
9	LD (Laser diode) power check					
				VR Ⓐ	Specified value 0.13 mW or less	<ul style="list-style-type: none"> <li>● Set the test mode. (*)</li> <li>● Press TRACK BACK key (◀) and turn the LD (laser diode) on.</li> <li>● Place the sensor of the light power meter directly above the objective lens and confirm that LD power is the specified value (0.13 mW or less).</li> </ul>

\* See page 49.

Step No.	Oscilloscope setting		Test points	Adjusting points	Check Items/ adjustment specifications	Adjustment procedure
	V	H				

10	<b>Focus gain adjustment</b>				
<p>CH1 (X) , CH2 (Y) 20 mV/div, 5 mV/div (probe 10:1)</p>	<p>X axis: TP1 Pin 5 (FO. IN) Y axis: TP1 Pin 6 (FO. ER)</p>	<p>VR3 (FO. GA)</p>	<p>Phase difference 90°</p>	<ul style="list-style-type: none"> <li>● With the power off, connect the oscilloscope and the oscillator as shown in Fig. 6.</li> <li>● Set the normal playback mode.</li> <li>● Turn the oscillators power on and set it to output a 1.2 kHz, 1 Vp-p signal.</li> </ul> <p><b>Note:</b> (Some oscillators output DC when turned ON. In that case, High gain connect the oscillator after turning it on.)</p> <ul style="list-style-type: none"> <li>● Adjust VR3 FO. GA (focus gain) so that the resurge waveform on an oscilloscope becomes a horizontal circle (phase difference 90° ).</li> </ul>	

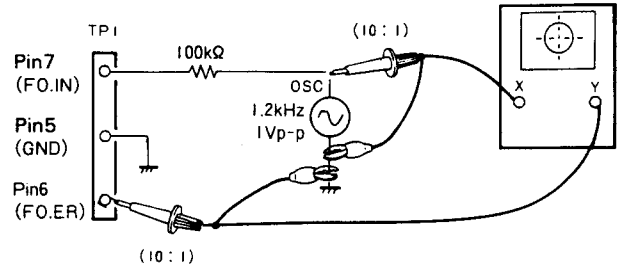
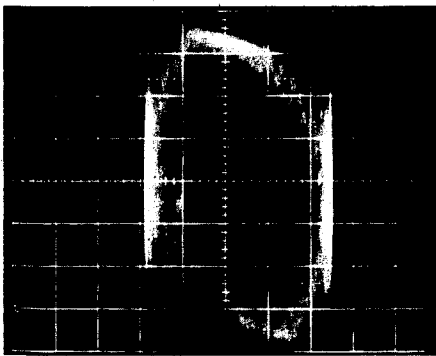
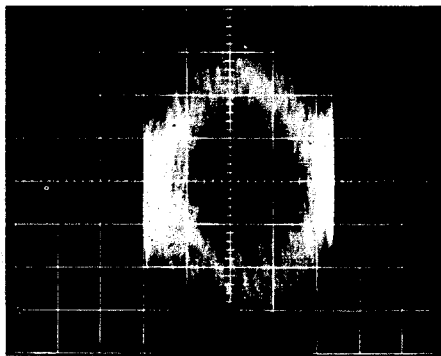

Fig. 6.



High gain  
Photo-11



Optimum gain  
Photo-12

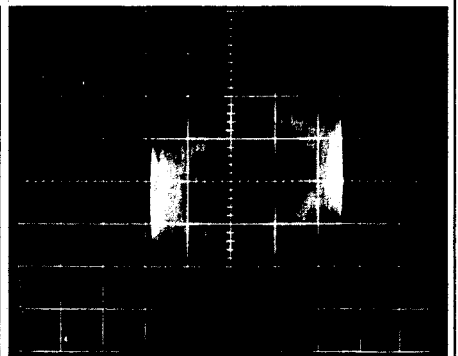

Low gain  
Photo-13

Step No.	Oscilloscope setting		Test points	Adjusting points	Check Items/adjustment specifications	Adjustment procedure
	V	H				
11	<b>Tracking gain adjustment</b>					
	CH1 (X), CH2 (Y) 50 mV/div, 5 mV/div (Probe 10:1)		X axis: TP1 Pin 3 (TR. IN) Y axis: TP1 Pin 2 (TR. ER)	VR4 (TR. GA)	Phase difference 90°	<ul style="list-style-type: none"> <li>● With the power off, connect the oscilloscope and the oscillator as shown in Fig. 7.</li> <li>● Set the normal playback mode.</li> <li>● Turn the oscillators power on and set it to output a 1 kHz, 2 Vp-p signal.</li> </ul> <p><b>Note:</b> (Some oscillators output DC when turned on. In that case, connect the oscillator after turning it on.)</p> <ul style="list-style-type: none"> <li>● Adjust VR4 TR. GA (tracking gain) so that the resurge waveform on an oscilloscope becomes a horizontal circle (phase difference 90°).</li> </ul>
					<p>Fig. 7.</p>	
						<p>High gain Photo-14</p> <p>Optimum gain Photo-15</p> <p>Low gain Photo-16</p>
12	<b>VCO free-running frequency adjustment</b>					
			TP3 Pin 2		Frequency 4.275 MHz ± 0.025 MHz	<ul style="list-style-type: none"> <li>● Set the test mode. (*)</li> <li>● Connect the frequency counter (10 MHz range) to Pin 2 of TP3.</li> <li>● Adjust VR8 (VCO. A) so that the frequency counter reads 4.275 MHz ± 0.025 MHz.</li> </ul> <p><b>Note:</b> Adjust with the stop mode.</p>

\* See page 49.

Step No.	Oscilloscope setting		Test points	Adjusting points	Check items/ adjustment specifications	Adjustment procedure
	V	H				
13	Focus error check					
	1V/div	2 ms/div	TP1 Pin 6 (FO. ER)	Check	Waveform	<ul style="list-style-type: none"> <li>● Set the test mode. (*)</li> <li>● Connect Pin 7 FO. IN (focus in) of TP1 to GND.</li> <li>● Press TRACK FWD key and check the waveform on Pin 6 FO. ER (focus error) of TP1 with the oscilloscope.</li> </ul>

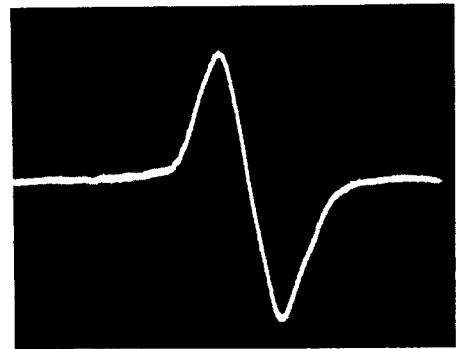

Focus error  
Photo-17

14	D/A converter adjustment					
			LINE OUT (L), (R) terminal	VR500 (Lch) VR501 (Lch) VR500 (Rch) VR501 (Rch)	Minimum distortion ratio	<ul style="list-style-type: none"> <li>● Set the test disc (YEDS-7) and connect the distortion meter to LINE OUT (L or R) of the main unit.</li> <li>● Play back the 1 kHz/0 dB signal and adjust VR500 and VR501 alternately so that the distortion ratio becomes minimum.</li> </ul>

**Note:** When a distortion meter is not available, cut the lead wires of R500 and R501 of the AUDIO MONAURAL BOARD ASSEMBLY using nippers and remove the resistors.

AUDIO MONAURAL BOARD ASSEMBLY

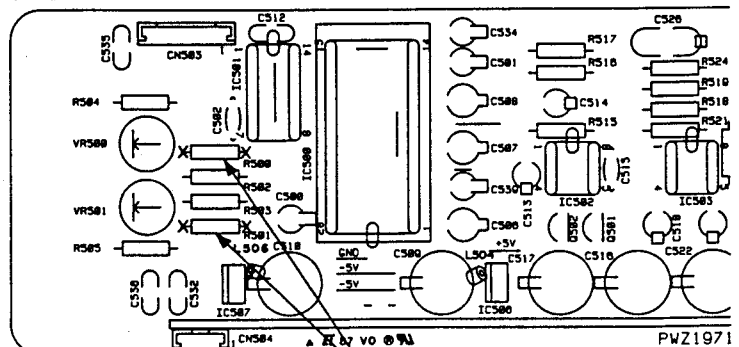

Cut the lead wires of R500 and R501 using nippers.

Fig. 8.

\* See page 49.

## 9. IC DESCRIPTIONS (CXD1165Q)

### Pin Descriptions

Pin No.	Name	I/O	Descriptions
1	FSW	O	Time constant selection output of spindle motor output filter.
2	MON	O	ON/OFF control output of spindle motor.
3	MDP	O	Drive output of spindle motor, rough control when CLV-S mode and phase control when CLV-P mode.
4	MDS	O	Drive output of spindle motor, speed control when CLV-P mode.
5	EFM	I	EFM signal input from RF amplifier.
6	ASY	O	Output to control slice level of EFM signal, "L" when stop.
7	LOCK	O	After sampling GFS signal in WFCK/16, if it is "H", "H" is output, and if it is "L" for eight successive times, "L" is output.
8	VCOO	O	VCO output, $f=8.6436$ MHz when locked to EFM signal.
9	VCOI	I	VCO input.
10	TEST	I	(0V)
11	PDO	O	Phase comparison output (compared EFM signal with $VCO/2$ ), "Hi-Z" when stop.
12	Vss	-	GND (0V)
13	CLK	I	Serial data transfer clock input from CPU, Data is latched at rising edge of clock.
14	XLT	I	Latch input from CPU, 8 bits shift register data (serial data from CPU) are latched to the respective registers.
15	DATA	I	Serial data input from CPU.
16	XRST	I	System reset input, reset when "L".
17	CNIN	I	Tracking pulse input.
18	SENS	O	Outputs internal condition according to address.
19	MUTG	I	Muting input, when ATTM of internal register A is "L", it is normal state at MUTG "L", and no sound state at "H".
20	CRCF	O	Outputs CRC check results of sub code Q.
21	EXCK	I	Clock input for serial output of sub code.
22	SBSO	O	Serial output of sub code.
23	SUBQ	O	Sub code Q output.
24	SCOR	O	S0+S1 output of sub code sync.
25	SQCK	I/O	Read clock of sub code Q.
26	SQEX	I	SQCK selection input. Refer to 1CPU interface.
27	DOTX	O	Digital output (WFCK is output when DO off.)
28	GFS	O	Display output of lock state for frame sync.
29	TEST	I	Fix to "H" or "L". Do not open.
30	TEST		
31	TEST		
32	TEST		
33	V <sub>DD</sub>	-	Power supply (+5V)
34	TEST	I	Fix to "H" or "L". Do not open.
35	TEST		
36	TEST		
37	TEST		
38	TEST		
39	TEST		
40	TEST		



Pin No.	Name	I/O	Descriptions
41	TEST	I	Fix to "H" or "L". Do not open.
42	TEST		
43	TEST		
44	TEST		
45	TEST		
46	TEST		
47	TEST		
48	TEST		
49	TEST		
50	TEST		
51	C4M	O	Crystal dividing frequency output, f=4.2336 MHz.
52	Vss	-	GND (0V)
53	XTAI	I	Crystal oscillation circuit input, f=8.4672 MHz or 16.9344 MHz by mode selection.
54	XTAO	O	Crystal oscillation circuit output, f=8.4672 MHz or 16.9344 MHz by mode selection.
55	MD1	I	Mode selection input 1
56	MD2	I	Mode selection input 2
57	MD3	I	Mode selection input 3
58	SLOB	I	Code selection input of audio data output, 2's compliment output when "L", offset binary output when "H".
59	PSSL	I	Mode selection input of audio data output, serial output when "L", parallel output when "H".
60	APTR	O	Control output for aperture compensation, "H" when R-ch.
61	APTL	O	Control output for aperture compensation, "H" when L-ch.
62	DA01	O	DA01 output (LSB of parallel audio data) when PSSL = "H", C1F1 output when PSSL = "L".
63	DA02	O	DA02 output when PSSL = "H", C1F2 output when PSSL = "L".
64	DA03	O	DA03 output when PSSL = "H", C2F1 output when PSSL = "L".
65	DA04	O	DA04 output when PSSL = "H", C2F2 output when PSSL = "L".
66	DA05	O	DA05 output when PSSL = "H", C2FL output when PSSL = "L".
67	DA06	O	DA06 output when PSSL = "H", C2PO output when PSSL = "L".
68	DA07	O	DA07 output when PSSL = "H", RFCK output when PSSL = "L".
69	DA08	O	DA08 output when PSSL = "H", WFCK output when PSSL = "L".
70	DA09	O	DA09 output when PSSL = "H", PLCK output when PSSL = "L".
71	DA10	O	DA10 output when PSSL = "H", UGFS output when PSSL = "L".
72	DA11	O	DA11 output when PSSL = "H", GTOP output when PSSL = "L".
73	Vdd	-	Power supply (+5V)
74	DA12	O	DA12 output when PSSL = "H", RAOV output when PSSL = "L".
75	DA13	O	DA13 output when PSSL = "H", C4LR output when PSSL = "L".
76	DA14	O	DA14 output when PSSL = "H", BLCK output when PSSL = "L".
77	DA15	O	DA15 output when PSSL = "H", BLCK output when PSSL = "L".
78	DA16	O	DA16 output (MSB of parallel audio data) when PSSL = "H", data output when PSSL = "L".
79	WDCK	O	Strobe signal output, 88.2 kHz.
80	LRCK	O	Strobe signal output, 44.1 kHz.

## 10. PANEL FACILITIES

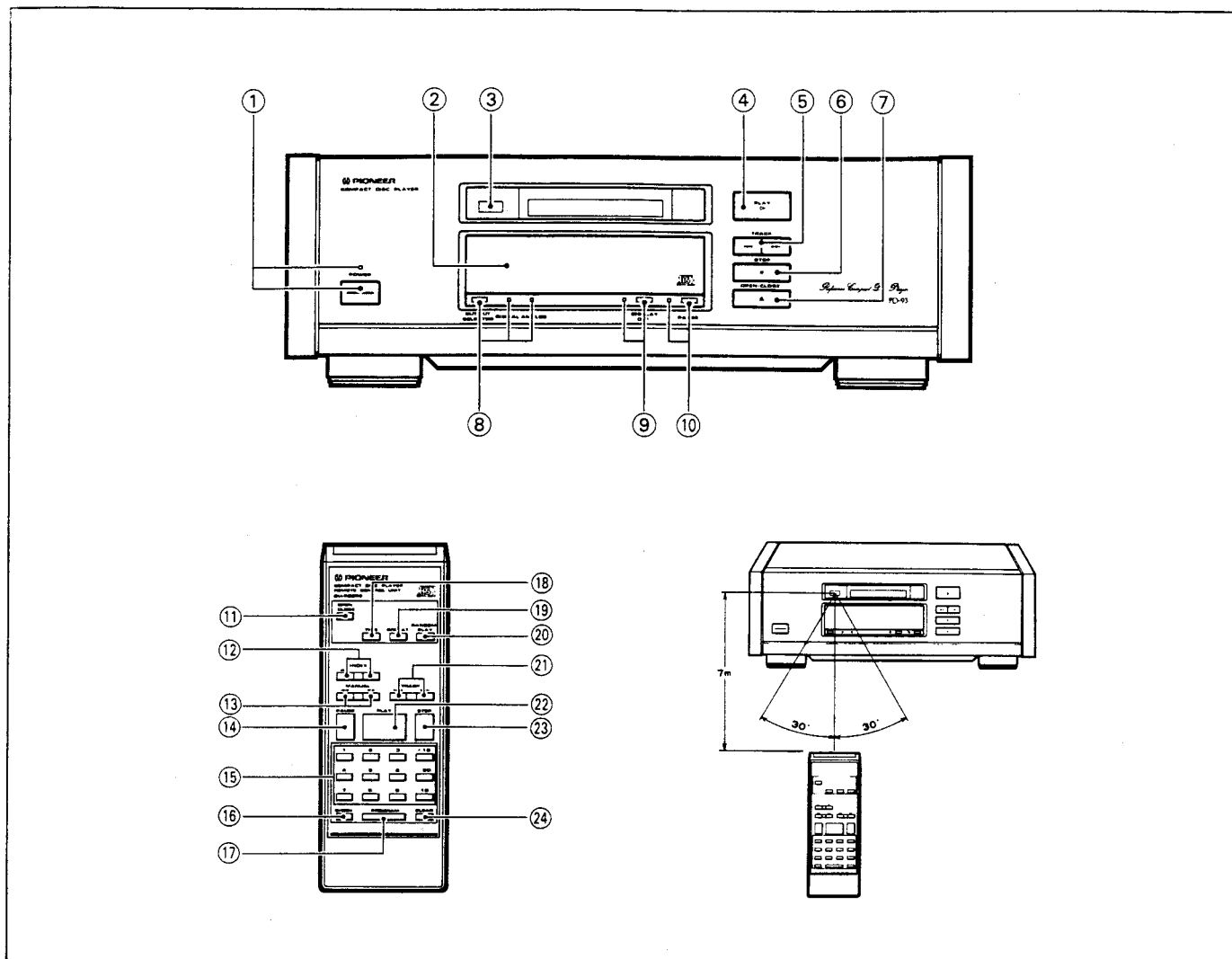

### FRONT PANEL

- ① **POWER switch/indicator**  
Press to turn power ON and OFF.
- ② **Disc tray**
- ③ **Remote sensor**
- ④ **PLAY button/indicator (▷)**
- ⑤ **TRACK search buttons (◀◀, ▶▶)**
- ⑥ **STOP button (■)**
- ⑦ **OPEN/CLOSE button (▲)**
- ⑧ **OUTPUT SELECTOR button/indicators**
- ⑨ **DISPLAY OFF button/indicator**
- ⑩ **PAUSE button/indicator**

### REMOTE CONTROL UNIT

Buttons listed here but not accompanied with explanations have the same functions as the corresponding front-panel buttons. If use is made of the supplied remote control unit, remote operation is possible.

To use the remote control unit, aim at the remote sensor. The remote control unit can operate over a range of approximately 23 feet (7 meters), within angles of 30 degrees left and right.

### NOTE:

If the remote control sensor window is in a position where it receives strong light such as sunlight or fluorescent light, control may not be possible.

- ⑪ **OPEN/CLOSE button**
- ⑫ **INDEX search buttons (←, →)**
- ⑬ **MANUAL search buttons (◀◀, ▶▶)**
- ⑭ **PAUSE button**
- ⑮ **Track number buttons (1-10, +10, ≥20)**
- ⑯ **CHECK button**
- ⑰ **PROGRAM button**
- ⑱ **TIME button**
- ⑲ **REPEAT button**
- ⑲ **RANDOM PLAY button**
- ⑲ **TRACK search buttons (◀◀, ▶▶)**
- ⑲ **PLAY button**
- ⑲ **STOP button**
- ⑲ **CLEAR button**

# 11. SPECIFICATIONS

## 1. General

Type ..... Compact disc digital audio system  
 Usable discs ..... Compact Disc  
 Power requirements  
   U.K. and Australian models ..... AC 240V, 50/60Hz  
   European model ..... AC 220V, 50/60Hz  
   U.S. and Canadian models ..... AC 120V, 60Hz  
   Multi-voltage model ..... AC 110/120–127/220/240V  
     (switchable) 50/60Hz  
 Power consumption ..... 30W  
 Operating temperature ..... +5°C – +35°C  
     (+41°F – +95°F)  
 Weight ..... 15.2kg (33lb, 8oz)  
 External dimensions ..... 459(W) × 435(D) × 151(H)mm  
     18-1/16(W) × 17-1/8(D) × 5-15/16(H) in.

## 2. Audio section

Frequency response ..... 2Hz–20kHz  
 S/N ..... 115dB or more (EIAJ)  
 Dynamic range ..... 99dB or more (EIAJ)  
 Channel separation ..... 110dB or more (EIAJ)  
 Total harmonic distortion ..... 0.0015% or less (EIAJ)  
 Output voltage ..... 2.0V  
 Wow and flutter ..... Limit of measurement  
     (±0.001% W.PEAK) or less (EIAJ)  
 Number of channels ..... 2 channels (stereo)

## 3. Output terminal

- Audio line output terminals
- Optical digital output terminal
- Coaxial digital output terminal

## 4. Functions

- Play
- Pause
- Stop
- Track search
- Manual search
- Index search
- Direct selection
- Single track repeat
- All track repeat
- Programmed repeat
- Random play repeat
- Programmed random play repeat
- Programmed playback (up to 24 steps)
- Pause program
- Program check
- Program correction
- Program clear
- Random play
- Programmed random play
- Time location
- Display off
- Timer start
- Digital/analog output select

## 5. Accessories

- Remote control unit ..... 1
- Size AAA/R03 dry cell batteries ..... 2
- Output cable ..... 1
- Operating instructions ..... 1

### NOTE:

*The specifications and design of this product are subject to change without notice, due to improvements.*

